

NEMA3R Sampler Enclosure

The Manning NEMA3R Sampler Enclosure is designed to provide excellent all-weather protection for your sampler. The enclosure is constructed of fiberglass-reinforced polyester on both sides of ¾-inch (19.05 mm) polyurethane insulation with a white gel-coated outer surface. The floor is reinforced with plywood or fiberboard and is level with the door opening. The following is a summary of the enclosure features and options:

Standard Features.

- Door has lockable handle and stainless steel continuous hinge on the right side.
- Two 4-inch (101.60 mm) diameter air vents with aluminum louvers, located on the lower right and upper left sides of the enclosure.
- Access holes for sampler intake hose (right side) and electrical power (left side)
- Two grounded duplex outlets for 110-VAC electrical power on left-side wall for convenient use with refrigerator, sampler and accessories.

Heater Option

110 VAC, 60 Hz, fan forced air heater (UL listed) with thermostat mounted on upper back wall. Heater has dual heat settings of 750 or 1500-watt, as well as a fan only setting. Internal high-limit thermostat and high-limit safety fuse. Plug is provided for use in duplex outlet.

Fan Option

110 VAC 60 Hz, 106 CFM tube axial fan mounted on inside of left wall over air vent to exhaust air out of enclosure. Fan is controlled by wall-mounted switch.

In order to provide adequate airflow for the refrigerator, Manning recommends the fan option for most installations.

Light Option

Vapor-tight light fixture uses a 100 W, 110 VAC light bulb mounted on inside left wall. Wall-mounted switch.

Notes:

With both heater and fan options installed, the NEMA3R Sampler Enclosure can protect your sampler and samples within an ambient outside temperature range of -40–122° F (-40–50° C).

The enclosure is designed for use with the Manning VSR, YB8, and S-5000 samplers. The enclosure can also accommodate the S-5200 sampler, but the clearances are very tight. For 220 VAC, 50 Hz applications, please consult the factory.

Approximate shipping dimensions and weight (enclosure only): 36" x 34" x 81" (914.40 mm x 863.60 mm x 2057.40 mm), 225 lbs (102.06 kg).

Enclosure should be installed on flat, level surface.

20-Amp, 110 VAC electrical service must be connected to the enclosure for a standard 110 VAC sampler,



YB8 Sampler in NEMA3R Enclosure with heater and fan options.

refrigerator and accessories. 220 VAC service is required if refrigerator or sampler is 220 VAC (*special option only, please consult factory*). Consult local electrical codes for proper wiring.

Caution: Only an experienced, properly licensed electrician should perform electrical wiring.

NEMA3R Enclosure Dimensional Drawings

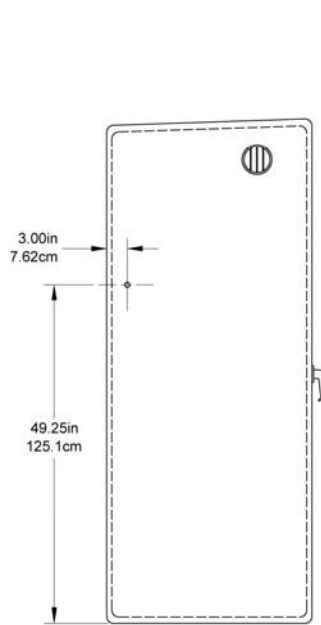
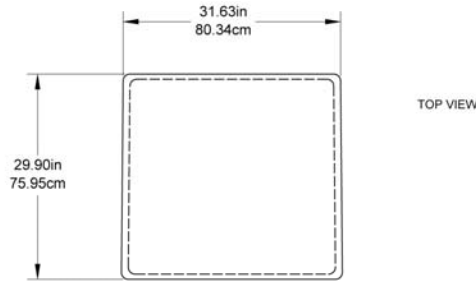

RIGHT SIDE VIEW

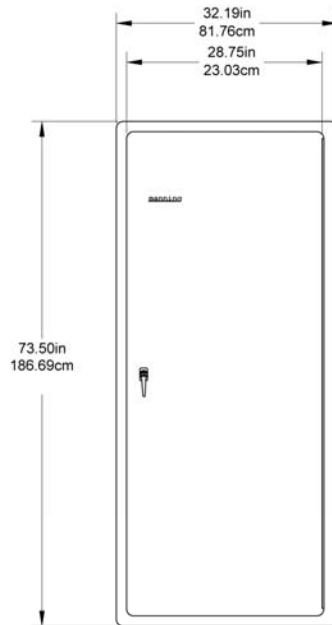

FRONT VIEW

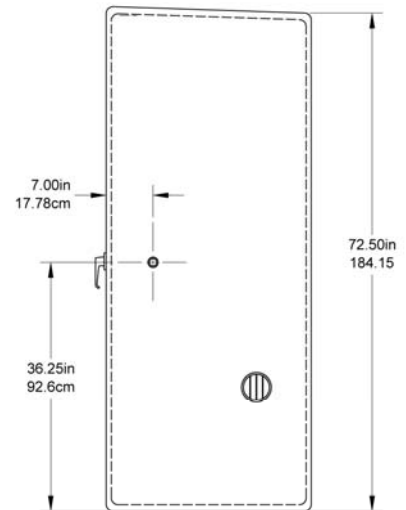

LEFT SIDE VIEW

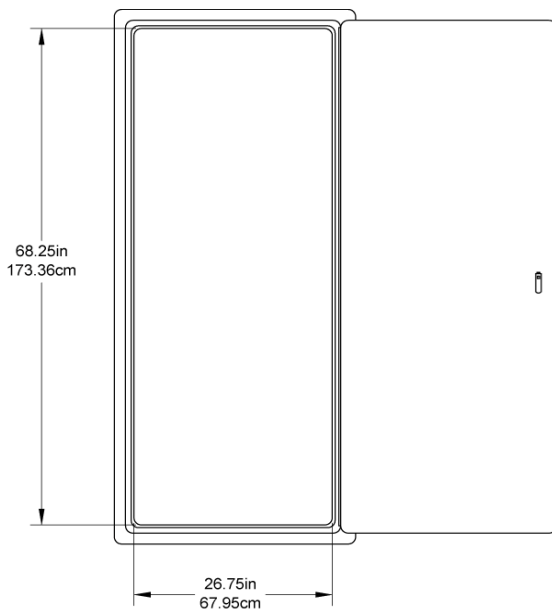

FRONT VIEW, DOOR OPENED

Note: All measurements are approximate. Due to the manufacturing process, measurements of individual units may vary slightly.

Headquarters and Sales:

Manning Environmental, Inc.

1968 South Austin Avenue
Suite 101

Georgetown, Texas 78626

Phone: (800) 863-9337

Fax: (512) 863-4472

Email: sales@manning-enviro.com

Web: www.manning-enviro.com

In the interest of improving and updating its equipment, Manning reserves the right to alter specifications to equipment at any time.