

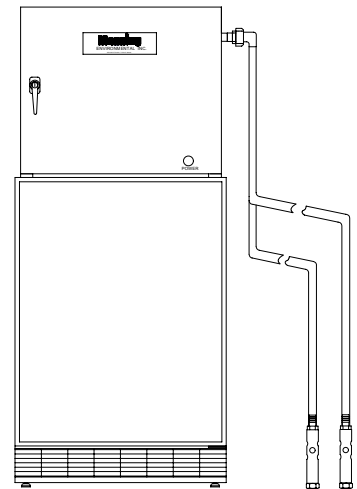

Operating and Instruction Manual

Manual No. MS717659
August 2003

MODEL S-5200 STATIONARY DUAL COMPOSITE VACUUM SAMPLER



Manning Environmental, Inc.
1968 S. Austin Ave.
Suite 101
Georgetown, Texas 78626 USA
Office: (512) 863-9337
Fax: (512) 863-4472
E-Mail: sales@manning-enviro.com

OPERATION AND MAINTENANCE
of
MANNING ENVIRONMENTAL, INC.

MODEL S-5200
STATIONARY DUAL COMPOSITE STAMPLER

Manual Part Number 717659

August 2003

Manning Environmental, Inc.
1968 South Austin Avenue
Suite 101
Georgetown, Texas 78626-7808
Telephone: 512-863-9337
Fax: 512-863-4472

Copyright 2003, by Manning Environmental, Inc.

All rights reserved. This work is protected by Copyright and other laws. Copying any aspect of this work is strictly prohibited.

Warning!

Dangerous electrical voltages are present in this equipment. Turn equipment off and disconnect power prior to servicing. Only qualified personnel should make electrical connections to the equipment

Caution

The pinch solenoid assemblies located underneath the measuring chambers close with great force. Do not place your fingers, tools or other items in their path while power is turned on.

Caution

Some fluids that are sampled may pose a health risk. Observe proper protective procedures when handling sample containers or any other parts of the equipment that has come in contact with the fluid.

Caution

The electronics enclosure and refrigerator are heavy. Observe caution when moving the equipment.

Manning Environmental Limited Factory Warranty

Manning Environmental, Inc., warrants this product to the original purchaser against any defects that are due to faulty workmanship or material for a period of one year (365 days) from the date of shipment.

During the warranty period Manning Environmental, Inc. will repair or replace, at its sole discretion, any defective equipment or parts. Manning's liability is strictly limited to repair and/or replacement. Any product repaired or replaced under this warranty will be warranted only for the remainder of the original product warranty period.

This warranty does not apply to consumable products or consumable components of products such as, but not limited to tubing, intake hose, differential pressure switches and bottles.

Items may not be returned without authorization from Manning Environmental, Inc.

This warranty applies only to products sold under the Manning trademark and is the sole express warranty made by Manning Environmental, Inc. All implied warranties, including without limitation, the warranties of merchantability or fitness for a particular purpose, are disclaimed.*

Limitations:

This warranty does not cover the following:

1. Damage caused by acts of God, natural disaster, labor unrest, acts of war (declared or undeclared), terrorism, civil strife or acts of any governmental jurisdiction
2. Damage caused by normal wear, neglect, misuse, accident, corrosion or improper application or installation
3. Damage caused by any repair, attempted repair or modifications not authorized by Manning Environmental, Inc.
4. Any product not used in accordance with the instructions furnished by Manning Environmental, Inc.
5. Freight charges to return merchandise to Manning Environmental, Inc.
6. Freight charges on expedited or express shipment of warranted parts or products.
7. Travel and lodging fees associated with on-site warranty repair
8. Manning 6.1 cubic foot refrigerators, which are covered under the refrigerator manufacturer's warranty
9. Labor performed at the factory to clean the equipment so that it can be safely and properly repaired

This warranty constitutes the final, complete, and exclusive statement of warranty terms. Manning Environmental, Inc. does not authorize any other person to make any other warranties or representations on its behalf.

In no event shall Manning Environmental, Inc. be liable for any incidental or consequential damages of any kind for breach of warranty or negligence. The remedies of repair or replacement as stated above are the exclusive remedies for the breach of this warranty.

**Some states within the United States do not allow the disclaimer of implied warranties and if this is true in your state the above limitation may not apply to you. This warranty gives you specific rights- you may also have other rights that vary from state to state.*

Table of Contents

Description	Page
INSTALLATION & OPERATION.....	1
Introduction.....	1
Hardware.....	1
General Description	2
The Electronics Enclosure	2
Wetted Parts Subassembly.....	7
Functional Description.....	9
Theory of Operation.....	12
Logic Board	12
Power Board.....	12
Installation	14
Refrigerator	14
Sample Container and Bottle Full Sensor.....	14
Connecting Power.....	14
Connecting an External Device to the Sampler (Flow-Based Sampling)	14
Sample Intake Line	15
Alarm Option	15
Flow-Through Cell Option	15
Intake Hose Placement.....	15
Running a Test (Manual) Cycle.....	16
Setting the Sample Size	16
Sample Recovery	17
Sampler Modes	18
Time Mode.....	18
Flow Mode.....	18
MAINTENANCE & TROUBLESHOOTING	19
Maintenance.....	19
Cleaning the Wetted Parts.....	19
Environmental Protection	20
Troubleshooting.....	23
Checking the Differential Pressure Switch.....	25
Checking the Pinch Solenoid.....	25
How to Return Equipment	26
OPTIONS, ACCESSORIES & SPARE PARTS	25
Alarm Board Option	28
Totalizer Option.....	30
Flow-Through Cell Option	35
Spare Parts & Accessories	39

List of Figures

Figure	Description	Page
1.	Manning S-5200 Stationary Composite Sampler	3
2.	S-5200 Side Views.....	4
3.	S-5200 Stationary Composite Sampler, Electronics Enclosure Mounted on Refrigerator	5
4.	Model S-5200 Operation Controls.....	7
5.	Measuring Chamber.....	8
6.	S-5200 Functional Block Diagram	11
7.	S-5200 Sampler Controller Block Diagram.....	13
8.	S-5200 Electrical Connections.....	15
9.	Intake Hose Placement.....	16
10.	Setting the Sample Size	17
11.	Model S-5200 Sampler Installation With Refrigerator.....	22
12.	Alarm Board.....	29
13.	Typical Alarm Board Wiring.....	29
14.	Dual Totalizers Mounted on the S-5200 Electronics Enclosure Door	30
15.	S-5200 Analog (4-20mA) Connections	31
16.	Totalizer Enclosure	31
17.	Flow-Through Cell	35
18.	Flow-Through Cell Operation	36
19.	Flow-Through Cell with Electrically Actuated Ball Valve	37
20.	S-5200 Wiring Diagram.....	42
21.	S-5200 Wiring Diagram with Totalizers	43
22.	S-5200 Air System Diagram.....	44

Installation & Operation

INTRODUCTION

Congratulations on your purchase of a Manning Environmental, Inc. Model S-5200 Stationary Dual Composite Vacuum Sampler. Your new S-5200 was designed to provide you with the easiest and most cost efficient way to take composite samples. Your S-5200 is backed by the Manning legacy of reliability and will provide you with years of dependable service.

Even if you do not intend to use the sampler immediately upon receipt, please unpack and examine it. Make sure you have received all of the parts you ordered and that no damage has occurred in shipment. This will also familiarize you with the equipment.

We recommend that you follow these steps before attempting to use your sampler:

1. Review this manual
2. Follow the instructions beginning on page 14 to install your S-5200.
3. Activate a test cycle.

HARDWARE

Functional Specifications

Temperature Limits:	0°C to 50°C (32°F to 122°F)
Maximum Lift:	22 ft (6.7 m)
Transport Velocity:	Minimum of 5 ft/s at 3 ft of lift (1.52 m/s at 1 m) and 2.5 ft/s at 20 ft of lift (0.76 m/s at 6.1 m)
Measuring Chamber Volume:	50 ml to 1 liter within 0.5% of preset volume
Size and Weight:	Height: 56.6 in. (145 cm)
	Width: 24 in. (61 cm)
	Depth: 24 in. (61 cm)
	Dry Weight: 160 lb (72 kg) with refrigerator
Power:	110-120 VAC, 60 Hz

About this Manual

Every effort has been made to insure that this manual is complete and accurate. Your comments and suggestions for improvement are welcome. Please contact Manning Environmental, Inc. to let us know what we can do better.

GENERAL DESCRIPTION

The Manning S-5200 Composite Sampler is a stationary dual-sampling unit designed for permanent facility applications where sampling from two separate sample sources is required.

The sampler contains two separate systems with identical components that can function independently of each other. Because each system has its own set of controls (with the exception of the Power Switch), samples can be taken simultaneously or staggered for intermittent sampling, as set at the control panel.

The S-5200 is designed so that metal parts, except the bottle full sensor probes never contact the liquid source or the samples, thus avoiding the possibility of metallic contamination of the samples.

The S-5200 is divided into three major sub-assemblies: the electronics enclosure, the refrigerator, and the wetted parts subassembly. As a unit, these sub-assemblies form an environmentally resistant enclosure that conforms to NEMA 4X. See Figures 1, 2, and 3.

The Electronics Enclosure

The electronics enclosure is gray polyurethane enamel coated heavy gauge metal assembly that is mounted on top of the refrigerator. A hinged door with a key lock provides protection against tampering or unauthorized changing or setting of controls. A lamp located on the outside lower right-hand corner of the door gives the operator a visual indication that power is applied to the sampler. A removable back panel allows access to internal components. The electronics enclosure contains all of the following:

Controller Electronics and Electrical Components.

The controller electronics and most of the sampler electrical components are located on the back of the central panel, which is mounted inside of the enclosure. With the exception of a few common components, each sampler system has its own controller electronics and electrical components. Each of the two controller's electronics consists of a logic board (which has the two dial controls mounted on it), and a power board. The electrical components consist of a power transformer and power line filter for each system. A terminal barrier strip with a power cord attached, and a 10 Amp circuit breaker that also serves as the sampler power switch are the common electrical components. Each system has an air compressor and a 4-way electrically operated air valve. Both air valves and one of the compressors are mounted to the back of the front panel. The second air compressor is mounted to the right side of the electronics enclosure, behind the front panel. Two electric pinch solenoids, one for each sampler system are located on a bracket mounted to the front of the central panel.

If the sampler is equipped with either the Alarm Option or the Totalizer Option, then these components are also installed in the electronics enclosure. Alarm Option's circuit boards are installed on the back of the control panel. The Totalizer Option's circuitry is installed in a housing mounted to the inside of the enclosure door. If your sampler is equipped with these options, refer to the Options, Accessories, & Spare Parts Section this manual.

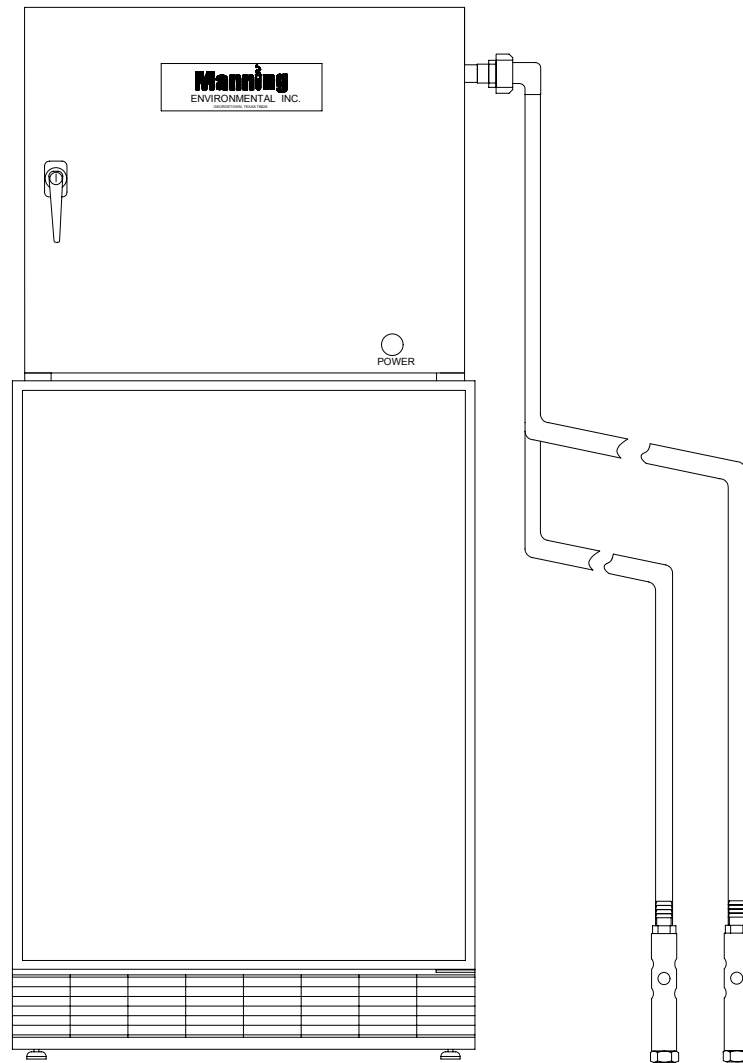

Figure 1. Manning S-5200 Stationary Composite Sampler

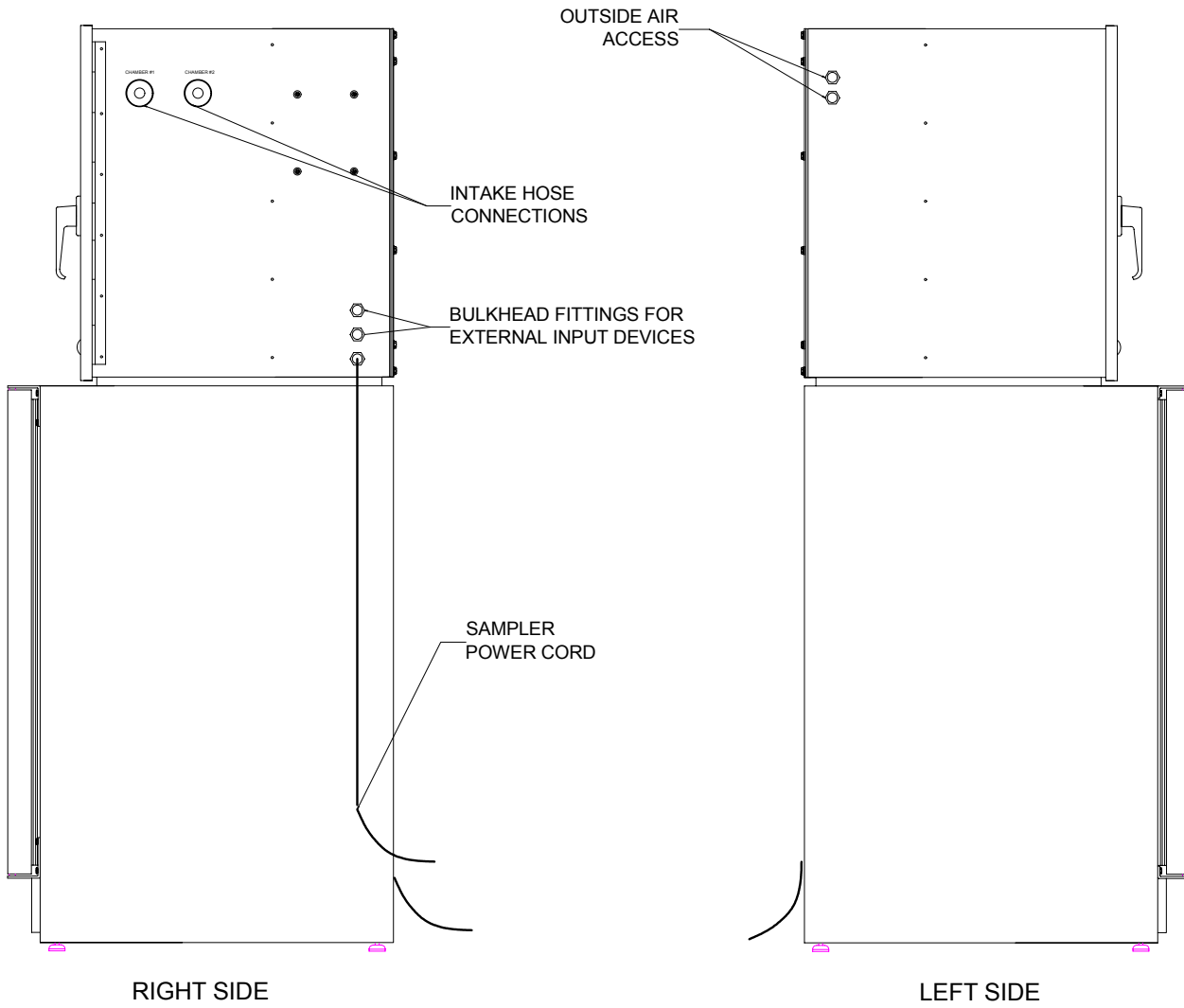

Figure 2. S-5200 Side Views

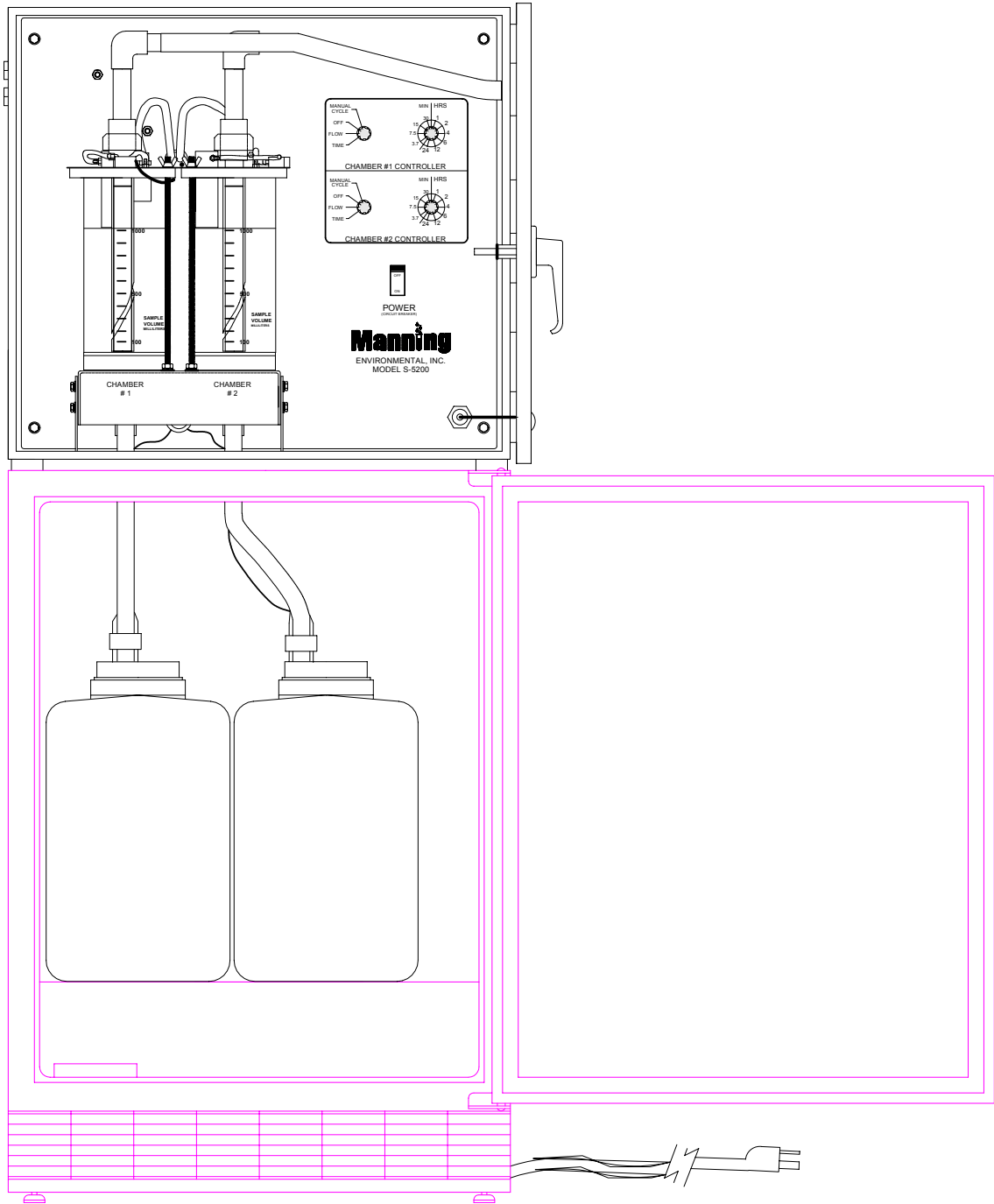

Figure 3. S-5200 Stationary Composite Sampler, Electronics Enclosure Mounted on Refrigerator

Operating Controls

Figure 4 shows a picture of the operating controls of the 5200. There are several parts that make up the operating controls.

- 1) Power ON/OFF Switch/Circuit Breaker: This two-position rocker switch turns the power to the system on and off. It also provides overload protection to the sampler (10 Amp circuit breaker).
- 2) Function Switch (one for each chamber): This four-position switch that can be set to any of the following settings:
 - a) MANUAL-CYCLE: Causes one manual sample to be taken.
 - b) OFF: Stops all sampler operation but does not disconnect the external (110 VAC) power.
 - c) TIME: Allows samples to be taken based on a single time interval set by the timer switch.
 - d) FLOW: Allows samples to be taken each time a momentary contact closure is detected from an external device such as a flow meter. If the sampler is equipped with the optional Totalizer, the Totalizer provides the momentary contact closure to the sampler controller based on a 4-20 mA signal supplied from an external device.

NOTE: If the contact closure remains closed while in the FLOW mode, the sampler will take additional samples based on the time interval set on the timer switch.

- 3) Timer Switch (one for each chamber): The timer dial allows you to set the time interval between samples when the function switch is turned to TIME. Can be adjusted to ten time intervals ranging from a 3.7-minute interval to a 24-hour interval between samples.

NOTE: If an external device such as a flow meter is connected to the sampler with the function switch set to TIME, the sampler will still take samples based on momentary contact closures from the external device.

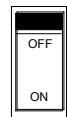
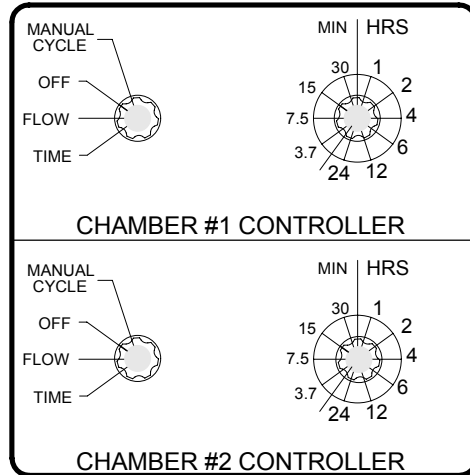

POWER
(CIRCUIT BREAKER)

Manning
ENVIRONMENTAL, INC.
MODEL S-5200

Figure 4. Model S-5200 Operation Controls

Wetted Parts Subassemblies

Wetted Parts are any components that come into contact with the sample. The wetted parts are all made of PVC, surgical grade silicone rubber, Lexan© or stainless steel. There are two sets of Wetted Parts, one for each chamber. The Wetted Parts are located in the front of the electronics enclosure and in the refrigerator.

Measuring Subassemblies

The measuring subassemblies include a transparent measuring chamber scaled in milliliters that is located between a chamber top and chamber base assembly. Silicone pinch tubing is attached to the bottom of the chamber base to provide a sample discharge path into the sample collection container. A pinch solenoid assembly is used to seal the chamber base by pinching the silicone tubing during portions of the sample cycle. These assemblies are located on a bracket mounted to the front of the control panel. The chamber top is connected to the intake line by a short hose that exits the right side of the enclosure. Air lines from the compressor through the 4-way valve supplies air pressure for purging and vacuum for drawing. A differential pressure switch assembly is also located on the chamber top and is used to signal the controller electronics when the chamber is full of fluid during a sample cycle.

Sample volume is adjusted by rotating the spiral tube extending from the bottom center of the chamber top. The sample volume is adjustable from approximately 50 to 1000 milliliters. The measuring chamber is shown in figure 5.

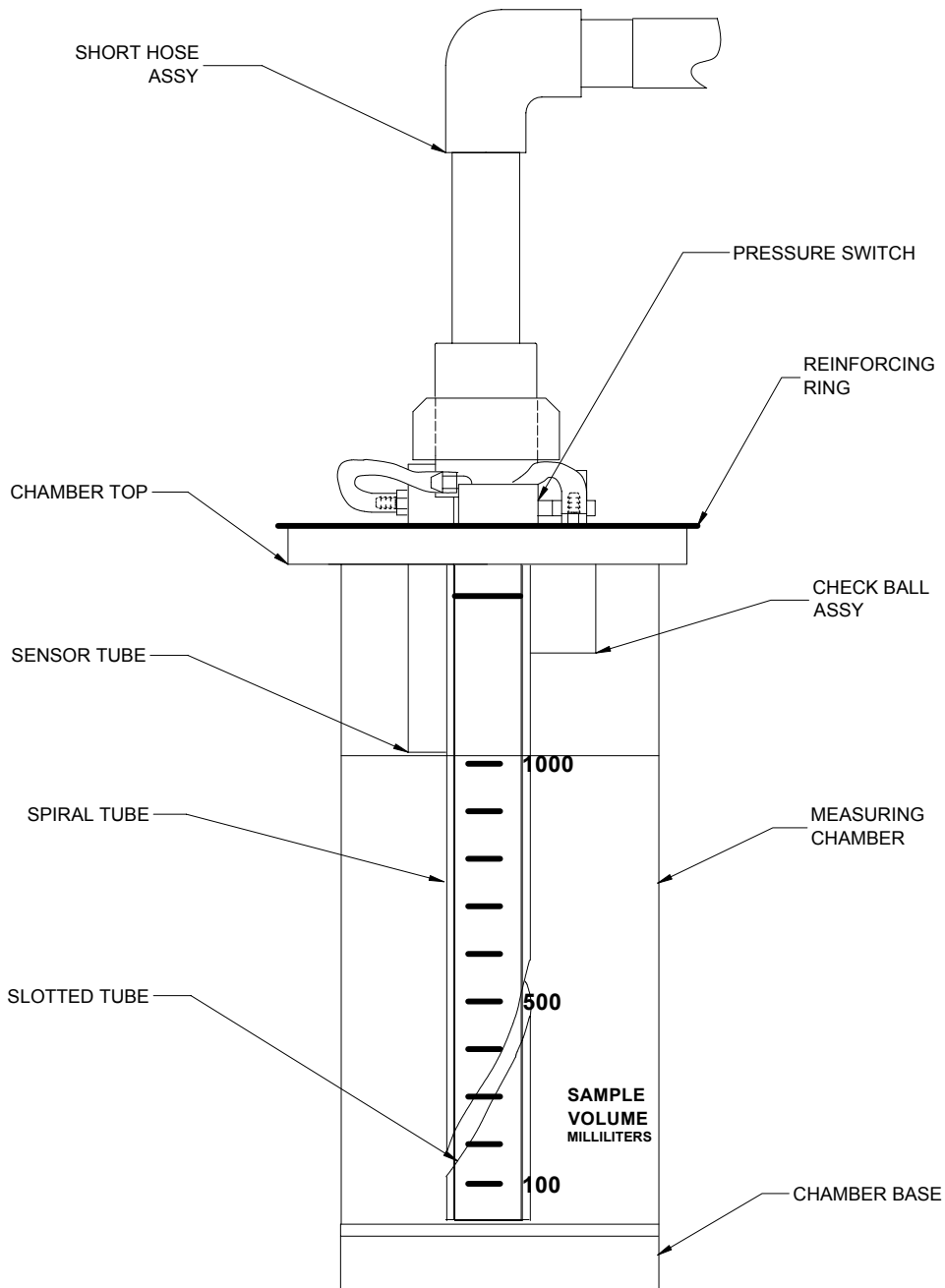

Figure 5. Measuring Chamber

Intake Lines

The intake lines are constructed of 5/8" inside diameter tubing. An optional weighted strainer at the end of the line prevents the suction of large particles into the intake line, which could plug the hose or part of the sampler. The weight of the strainer also keeps the hose at the desired level in the liquid to be sampled.

Each of the two intake lines are connected to short hoses with fittings on the outside of the electronics enclosure. The short hoses, in turn, are connected to their respective chamber tops.

Refrigerator Subassembly

In most sampling applications, it is necessary to maintain the collected samples at a constant temperature. In these instances, the sample containers are stored in a specially treated industrial grade refrigerator, with the sampler electronics enclosure mounted on top. This refrigerator is designed to maintain samples at a constant EPA recommended 4°C. The refrigerator is either painted with a corrosion resistant enamel (white), or is Stainless Steel. An optional factory-installed heater assembly is available for the refrigerator to prevent freezing of the sampled fluid in areas where the temperature will drop below freezing and the sampler is not in a climate-controlled location.

FUNCTIONAL DESCRIPTION

Note: The dual sampling systems of the S-5200 Composite Sampler are identical in form and function; therefore the following description applies to both systems.

The sampling cycle consists of purge, draw, measure, and deposit. See Figure 6 for a functional block diagram.

At the beginning of each sampling cycle, the pinch solenoid is energized, which seals off the chamber base. The compressor is started, which causes air to flow through the 4-way valve and into the measuring chamber. With the chamber base closed off, the pressurized air is forced out through the intake hose to purge the line of possible obstructions. Then, the 4-way valve is energized, which changes the airflow through the chamber from pressure to vacuum. Air is now being pumped out of the chamber through the 4-way valve by the compressor (an air line mounted to the top rear of the left side of the completes the air path). Fluid is now drawn up the intake line and into the chamber.

A differential pressure switch, mounted on the top of the chamber, signals the controller when the chamber is full of fluid. The high port of the pressure switch is connected to the chamber top's sensor tube that protrudes down into the chamber. The low port of the pressure switch is connected to the chamber top. When fluid fills the chamber to the point where the bottom of the sensor tube is covered, there is a difference in pressure between the high and low ports of the pressure switch. The pressure switch's internal electrical contacts close, which tells the controller that the chamber is full.

With the measuring chamber full, the controller turns the 4-way valve off. This again reverses the air flow to the chamber from vacuum (draw) back to pressure. The air forces the excess fluid out of the chamber through the intake line to the sample volume set by the position of the spiral tube on the chamber top. The controller then turns the pinch solenoid off, which opens the chamber base, allowing pressure to discharge the sample out the chamber into the sample bottle. The compressor is then turned off, ending the sample cycle.

A bottle full sensor is positioned on the pinch tube to prevent overfilling of the sample container. When its two Stainless Steel probes make contact with the fluid in the container, the controller will not allow any more samples to be taken until the bottle is emptied.

The sample cycle purge, draw, measure and deposit times are set by the software contained in FLASH memory on the controller's logic board. A jumper on the logic board allows for selection of two different sample cycle times- 30- second draw and 90-second draw, to meet various sampling needs. If the controller does not receive a "chamber full" signal at the end of the draw time, it will purge and then draw a second time. If after the second draw attempt the chamber has not been filled with fluid, the sampler purges the intake line, and then turns the pinch solenoid and air compressor off, completing the sample cycle. The following are the sample cycle times:

Sample Cycle	30-second draw Logic board	90-second draw Logic board
Purge	12 sec	37 sec
Draw	30 sec	90 sec
Measure	13 sec	45 sec
Deposit	17 sec	25 sec

Note: Draw times refer to the maximum time the sampler will attempt to draw the sample. The actual draw time depends upon how long it takes to fill the chamber. Due to tolerances in the electronic components on the logic board, the sample cycle times may vary slightly.

Flow

With the function knob in the FLOW position, the S-5200 Sampler can be driven by an external device providing a momentary (approximately ¼ second) contact closure to provide flow-proportional sampling. If the contact closure remains closed, the sampler will take samples based on the time interval selected on the time control knob. The contact closure must be 1K Ohms or less.

Time

Ten sampling intervals, from 3.5 minutes to 24 hours, can be selected using the TIME selector switch on the front panel. With the function switch set to TIME, placing the POWER switch to ON will immediately start the sampling cycle and automatically initiate a new sampling cycle at the end of each time frame. If an initial (immediate) sample is not desirable, turn the POWER switch ON, then place the function switch to the TIME position. This sequence delays the sample command for the time period set on the Time switch. Thereafter, at each elapsed interval, the sampler will automatically initiate a new sample cycle.

NOTE: A momentary contact closure will activate a sample cycle when the unit is in TIME mode.

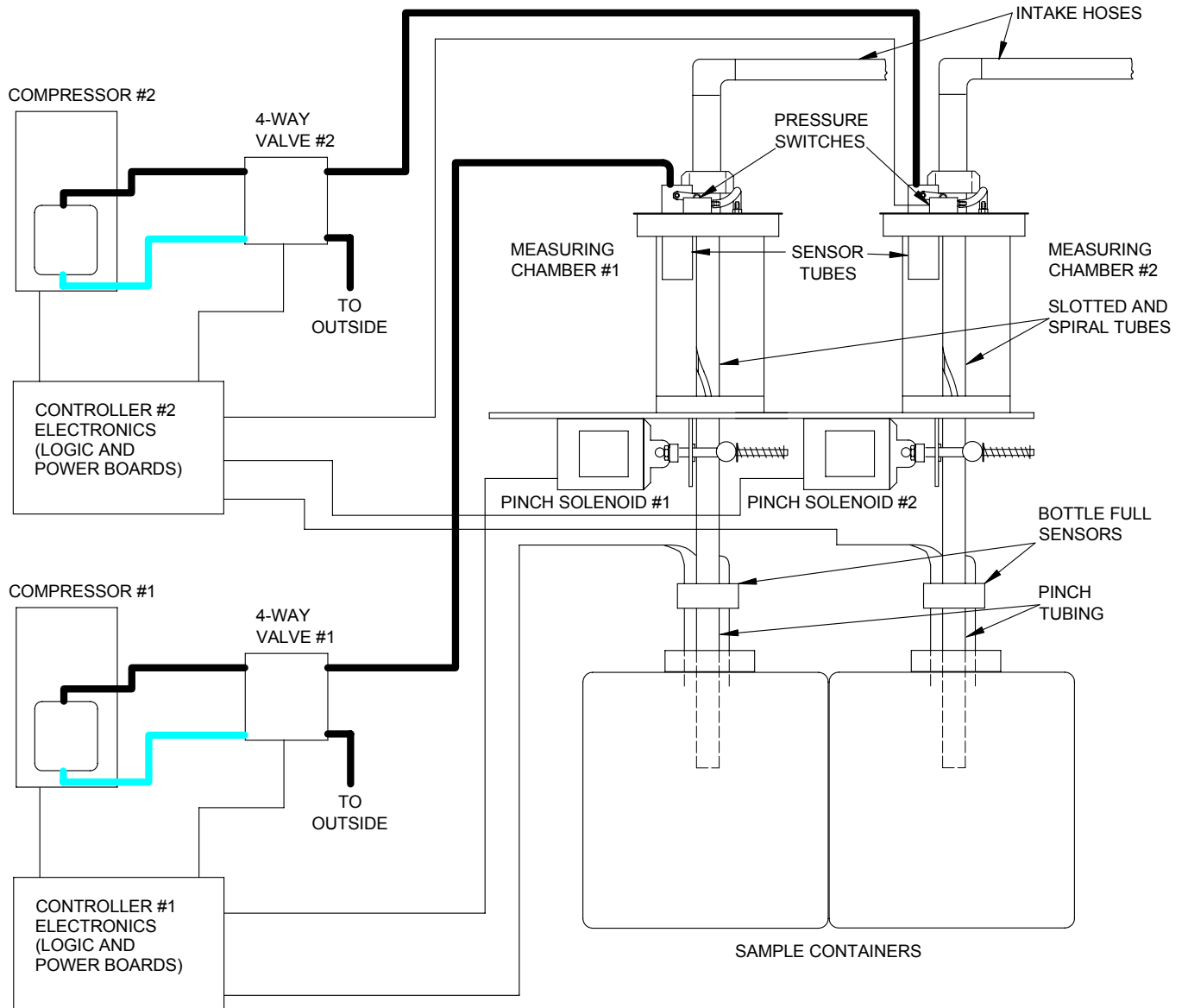

Figure 6. S-5200 Functional Block Diagram.

THEORY OF OPERATION

Two printed circuit boards make up each of the sampler's two electronic controllers. The logic boards are mounted to the back of the control panel by their rotary switches (Function and Time). The power boards are mounted in a bracket on the back of the control panel, where they plug into 36-pin card edge connectors. Figure 7 is a block diagram of one controller.

Logic Board

The logic board contains an 8-bit microcontroller with 64 Kilobytes of FLASH memory and 4 Kilobytes of static ram. Also contained on the board are +5 VDC and +3.3 VDC voltage regulators that supply operating voltages for the board. Level translator circuitry on the logic board allows it to interface with the +12VDC signals used on the Power Board. It is connected to the Power Board by a 14-pin Dual Inline Pin (DIP) connector and 10-wire ribbon cable.

The microcontroller's built-in FLASH memory contains the program data to operate the sampler (i.e., run the sample cycles). Internal timers provide accurate sample cycle and sample interval times.

Power Board

The power board contains a +12 VDC supply; power control circuits for the compressor, 4-way valve, and pinch solenoid; and paths to the logic board for bottle full, chamber full, Flow and Time signals.

Low voltage AC from the transformer secondary is rectified and regulated to produce the +12 VDC power. This supply is used to power the logic board.

The power control circuits control AC voltage to the compressor, 4-way valve and pinch solenoid. They receive AC line voltage from the power line filter and low voltage AC from the transformer secondary. The logic board provides the input controls signals for these three circuits.

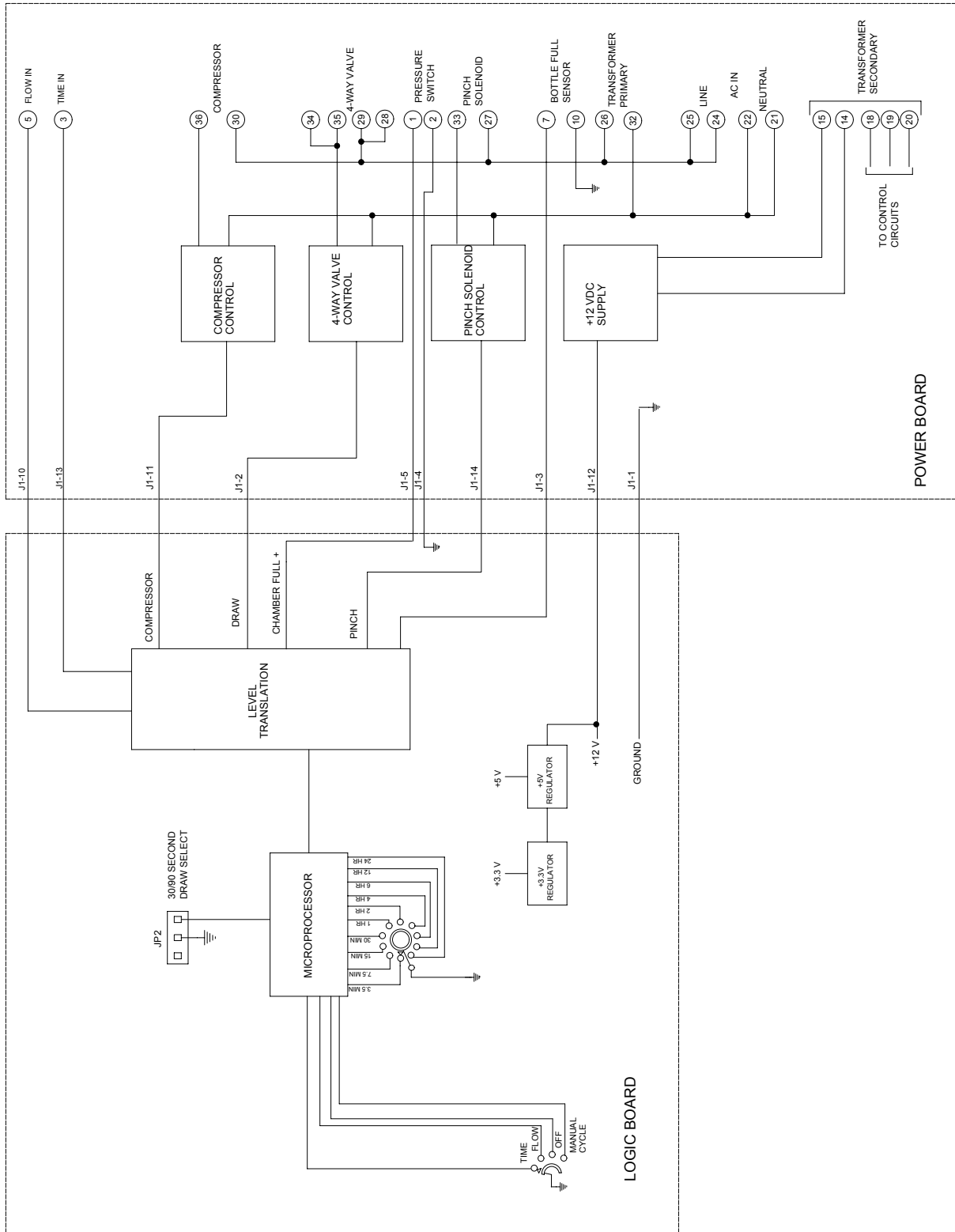

Figure 7. S-5200 Sampler Controller Block Diagram

INSTALLATION

Install the sampler on a firm, level surface adjacent to the sampling point. The sampler must be located at a point higher than the maximum anticipated fluid level (head height). The sampler must also be installed in a location with sufficient drainage so that water will not pool around the base of the sampler/refrigerator. In most cases the S-5200 comes fully assembled to make installation quick and easy. If the sampler is installed outdoors, you should enclose it in a shelter. This is especially important in areas where temperatures drop below freezing or other adverse weather conditions are expected. Manning offers an optional full-sized NEMA 3R fiberglass enclosure designed to protect the sampler. The NEMA 3R enclosure can be ordered with an optional heater, light, and/or fan.

If the sampler was ordered with an NEMA 3R enclosure, the enclosure should be positioned first and electrical power should be connected to it. Then, place the sampler into the enclosure. In most cases, the samplers with refrigerators come assembled (electronics enclosure mounted on top of refrigerator). If mounting of the electronics enclosure is required, refer to the Maintenance Section of this manual for instructions.

Refrigerator

Refer to the instruction manual accompanying the refrigerator for detailed instruction on its operation. Install the four adjustable feet on the refrigerator by screwing them into the threaded holes in the four corners on the bottom of the refrigerator. Adjust the feet to level the refrigerator. After power has been connected to the refrigerator (see Connecting Power below), adjust the refrigerator's thermostat for the proper temperature. Allow the refrigerator to run for 24 hours to stabilize its temperature.

Sample Containers and Bottle Full Sensors

Position the sample containers so that their respective pinch (discharge) tubes are inside of their openings. The bottle full sensors are designed to friction-fit against the outer wall of the pinch tube. Insert the pinch tubes through the center of the bottle full sensor rings and position the bottle full sensors so that their probes are below the top of their respective sample containers by at least the volume of one sample. (Note: Once a sample has been drawn into the chamber, it cannot be completely purged out. Therefore, allowing extra space in the sample container helps to prevent over filling.) Attach the two wires from the bottle full sensor cables to the short ends of their respective sensor probes by firmly pushing the female crimp terminals onto the probes. The bottle full sensor cables are marked with bands to identify them as #1 or #2.

Connecting Power

AC power cords (one for the sampler electronics enclosure and one for the refrigerator) are provided with the sampler. The sampler can also be hardwired, although an electrician should always do hard wiring. Connect the sampler to 120VAC, 60HZ power, with ground. Failure to provide proper grounding for the sampler or connecting the sampler to an improperly wired power outlet (line and neutral reversed) will cause the sampler to operate erratically and possibly damage it.

Connecting an External Device to the Sampler (Flow-Based Sampling)

For flow-proportional sampling, the external device that will trigger the sampler (contact closure) is connected to the sampler's TB-1 Terminal Board. See figure 8. Factory-installed pigtailed wires are provided to allow easy connection to the external device. The pigtailed wires are located above the power cord on the right side of the electronics enclosure. For installations where direct wiring is required, remove the pigtailed wires and watertight bulkhead connectors and connect wires directly to TB-1. Note: for samplers equipped with the

Totalizer Option, refer to the Options, Accessories, & Spare Parts Section in this manual for connection instructions.

Immediate Sampling

Connect wires to the FLOW and COMMON terminals on TB-1 (this is the normal factory setup). A sample will be taken immediately on contact closure.

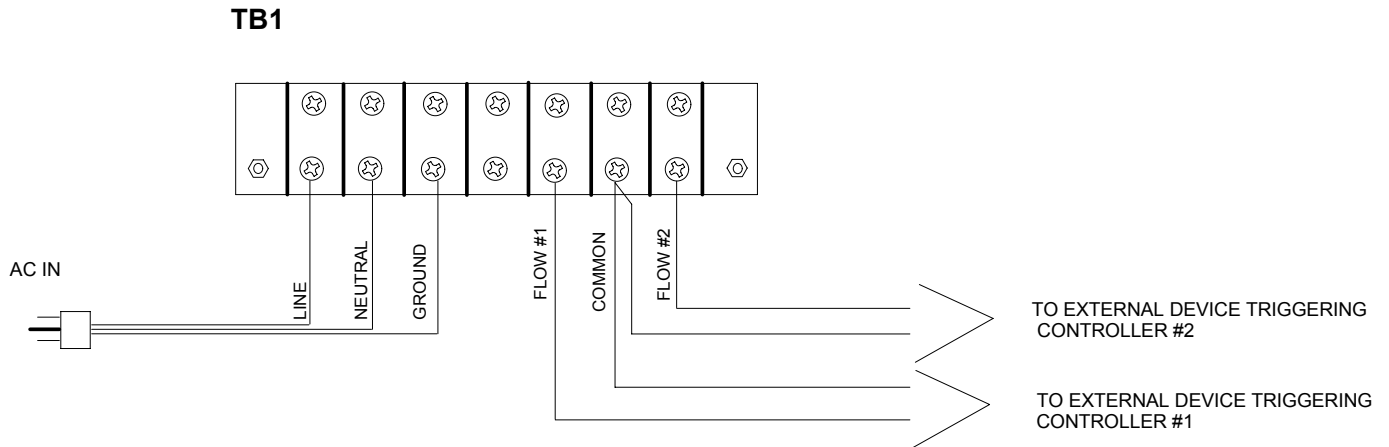

Figure 8. S-5200 Electrical Connections

Sample Intake Lines

Attach the intake hoses to the short hoses on the side of the sampler by threading the female fittings on the intake hoses onto the male fittings on the short hoses. If the sampler is installed in a NEMA 3R enclosure, route the other end of the hose through the hole in the side of the enclosure. In areas where the temperature may drop below freezing for extended periods of time, insulating the intake hoses will aid in preventing icing. Shading the intake hoses from sunlight will help prevent algae from growing inside of them in applications where that is a concern.

Alarm Option

If your sampler is equipped with the Alarm Option, refer to the Options, Accessories, & Spare Parts Section of this manual for information on Alarm operation and connections.

Flow-Through Cell Option

The flow through allows the sampler to be used with pressurized sources. If your sampler was ordered with the Flow-Through Cell Option, refer to Options, Accessories, & Spare Parts Section for detailed information.

Intake Hose Placement

Place the intake hose strainer directly in the channel flow, not in an eddy or at the edge of the flow. In channels with debris, provide deflection to prevent clogging of strainer holes. The weight supplied with the intake hose is usually sufficient to prevent the intake from being pulled to the surface of a fast channel.

The correct vertical position of the strainer depends on the type of sample being taken. Placing the strainer at the bottom of the flow results in a heavier concentration of solids in the sample, while placing the strainer at or near the top of the flow results in heavier concentration of oils, fats, and other floating or suspended

contaminants.

The intake hose should be positioned so the hose can drain between sample cycles and no low spots exist which would trap water. It may be necessary to cut the hose to length for proper placement. Figure 9 shows correct and incorrect hose placement.

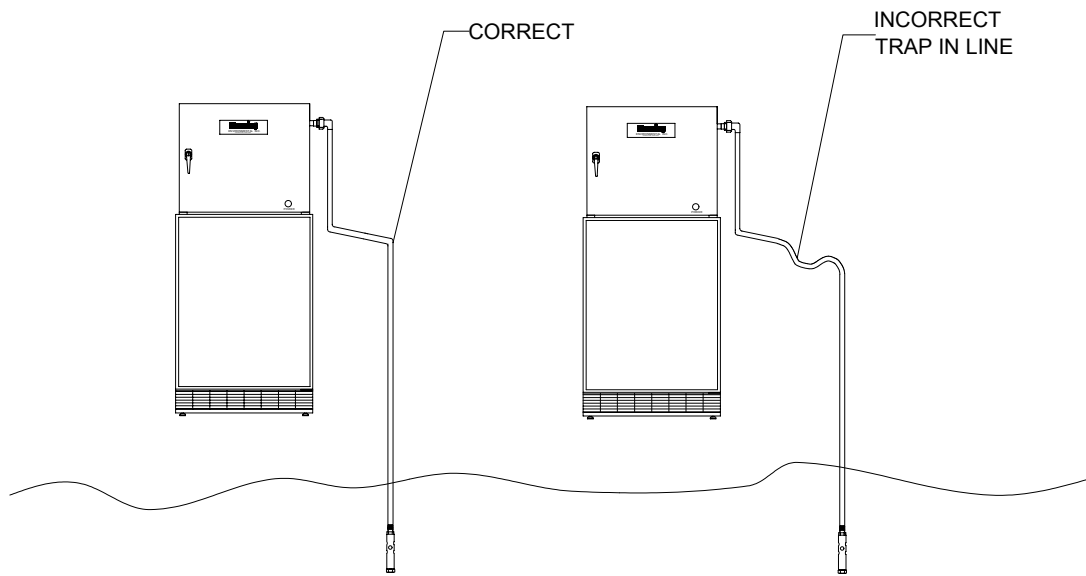

Figure 9. Intake Hose Placement

RUNNING A TEST (MANUAL) CYCLE

The Manual Cycle position on the Controller Function switch allows the operator to initiate one sample cycle to test the sampler operation or collect a manual (“grab”) sample. While it is not mandatory that you run a test cycle, it is recommended to assure proper operation and to familiarize you with the sampler operation.

1. Turn both Function Switches on the Controller to OFF. Then turn the main power switch on the central panel to the “ON” position.
2. Submerge the strainers of the intake hoses in a container of clean water. The amount of water should be enough to keep the strainer covered completely for several test cycles.
3. Turn the Function Switch on Chamber #1 Controller to MANUAL-CYCLE.
4. After the sample cycle has been completed, turn the Function Switch to OFF.
5. Repeat Steps 3 and 4 for Chamber #2.

SETTING THE SAMPLE SIZE

1. Remove the two wing nuts securing Chamber #1 chamber top, and lift the chamber top slightly.
2. Twist the spiral tube so that its opening aligns with the inner slotted tube at the level corresponding to

desired sample volume. See Figure 10. Make sure the spiral tube stays seated up against the bottom of the chamber top.

3. Replace the chamber top and verify the alignment with the graduations on the chamber.
4. Replace the wing nuts and tighten finger-tight, making sure all o-rings are evenly compressed and will seal.
5. Activate a manual cycle.
6. Measure the sample deposited.
7. Repeat steps 1 - 6 as needed to fine-tune sample volume.
8. Repeat steps 1 - 7 for Chamber #2

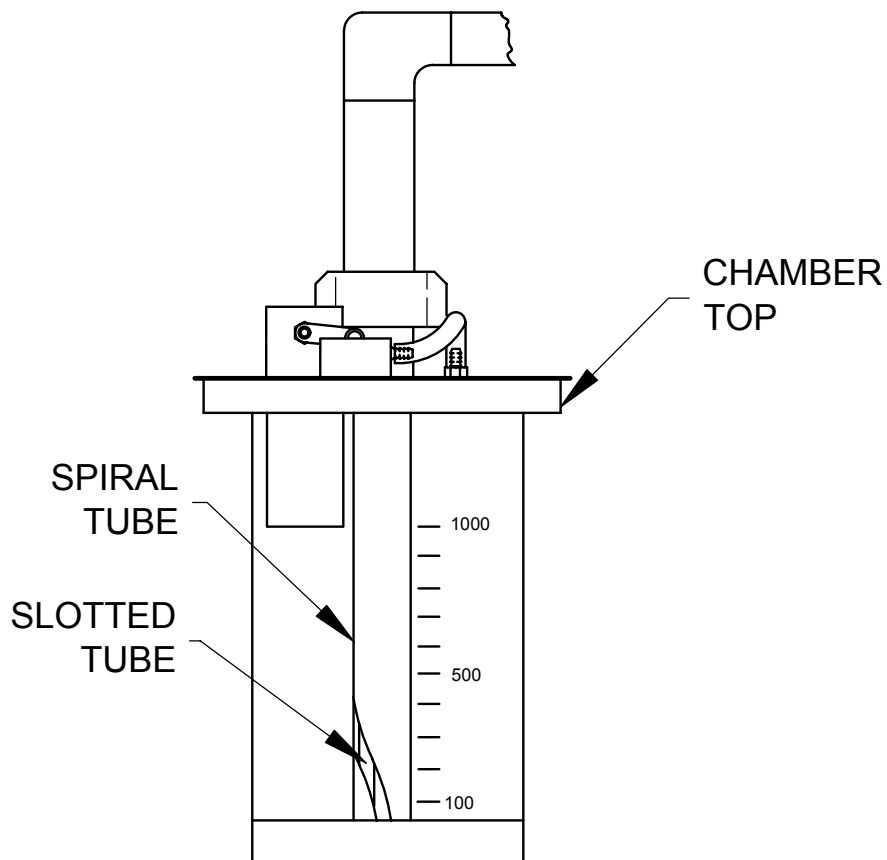

Figure 10. Setting the Sample Size.

SAMPLE RECOVERY

Immediate sample recovery is not required since the sampler will automatically shut down when the sample container is full. However, sample analysis may require quick recovery to maintain sample freshness or to add chemicals.

SAMPLER MODES

Once the sampler is installed, the operator then sets up the controls for the type of sampling operation desired. Sampling is based on time, flow or a combination of both. Refer to the Function Description and Electrical Connections sections for more information.

Time Mode

This mode allows you to take a sample after time period you set has elapsed. Once a sample is taken, the timer resets and begins to count down the time period until the next sample event. Turning the Function Switch to TIME and then setting a sample time interval on the Timer Switch puts the sampler in Time Mode. The Timer Switch can be set to take a sample every 3.7, 7.5, 15, or 30 minutes, and 1, 2, 4, 6, 12, or 24 hours. If a sample is desired immediately after the Sampler is set, set the Function and Timer Switches while the Power Switch is in the OFF position. When the sampler is turned ON, a sample will immediately be taken and then additional samples will be taken after each time interval elapses. If a sample is not desired until after the first timer interval has elapsed, set the Function and Timer Switches while the Power Switch is set to ON. The sampler will then take the first sample after the time period set on the Timer Switch has elapsed.

Flow Mode

When the Function Switch is set to the FLOW mode, the S-5200 will take a sample for each momentary dry circuit contact closure it receives from an external device (connected to the FLOW and COMMON terminals of TB-1). The contact closure must be 1K ohms or less. If the contact closure remains closed, the sampler will revert to time mode and will take one sample for each time interval set on the Timer Switch.

Maintenance & Troubleshooting

MAINTENANCE

Your sampler requires only minimal maintenance to ensure proper and reliable operation.

Cleaning the Wetted Parts

1. Standard PVC wetted parts are not autoclavable.
2. The wetted parts should be cleaned when they are coated.
3. Placing the intake hose in a container of clean water and running several test cycles can accomplish a quick cleaning of the wetted parts.
4. The use of some solvents to clean the wetted parts may leave a residue that could contaminate your sample. Additionally, some solvents will break down Polyethylene and/or PVC.
5. Keep the bottle full sensor dry and free from build up.
6. Leaks should be repaired immediately.
7. Clean up any spilled fluid inside the electronics enclosure and refrigerator.
8. The refrigerator has an auto-defrost feature. If ice builds up in the refrigerator, it should be removed.
9. Observe the operation of the sampler during normal operation or by running a Manual Cycle to insure that it is operating correctly.

Note: Solvents and solvent contaminated fluids must be disposed of according to approved procedures.

Intake Hose

1. Remove the intake hose. Remove the strainer if necessary.
2. Wash the intake hose and strainer using a cleaning solution appropriate for your installation. The use of methylene chloride or other solvents may leave a residue that could contaminate your sample. Use a test tube brush to scrub the internal surfaces of the strainer, pull the brush through the hose with a wire to clean the internal surfaces of the hose.
3. Rinse the hose and strainer thoroughly in clean water and reassemble.

Measuring Chamber

Caution: Do not allow water to enter the differential pressure switch. Remove the pressure switch and its tubing before cleaning the chamber top. Unplug the tubing for additional protection. Failure to keep the pressure switch dry will result in switch failure.

1. Remove the short intake hose connection from the chamber top by unscrewing it.
2. Remove the air line from the chamber top by pressing down on the quick-release ring on the fitting while pulling the air line.
3. Remove the two wires from the pressure switch by carefully removing the spade terminals from the pressure switch.
4. Remove the two wing nuts from the top of the measuring chamber and lift the chamber top and chamber top support ring off the chamber.
5. Remove the measuring chamber by lifting it off of the chamber base and clear of the chamber top.
6. Remove the silicone tubes that connect the pressure switch to the chamber top at the chamber top fittings. The chamber top support ring with the pressure switch can now be separated from the chamber top.
7. Check the two measuring chamber o-rings, one on the chamber top and one on the chamber base, for gouges and imperfections. Replace the o-rings if necessary. Do not lubricate these o-rings.
8. Wash the chamber parts with an appropriate cleaning solution. A test tube brush can be used to scrub the

- internal surfaces of the top fittings, slit tube and sleeve. Clean the chamber base and pinch tube.
9. Rinse all parts thoroughly in clean water. Blow water out of all tubing.
 10. Inspect the o-ring on the chamber top slotted tube (remove the spiral tube if necessary) for gouges and imperfections. Replace if necessary. Lubricate this o-ring with an appropriate silicone o-ring lubricant.
 11. Reassemble all parts.

Pinch Tubing

1. Inspect the pinch tubing for cracks and stiffness. Replace if necessary.
2. The pinch tubing is attached to the chamber base by a spring clip. Use a pair of pliers to loosen and slide the clip off of the chamber base. Then, remove the pinch tubing.

Environmental Protection

Once a year (or as necessary) replace the two vapor capsules located in the back of the electronics enclosure. If the sampler is in an area of high humidity, you may use additional desiccant at your discretion.

Other Maintenance Actions

The following instructions are provided to assist in maintaining the S-5200 Sampler.

Accessing Electronics Enclosure Internal Components

To access the internal components (such as TB1) inside the electronics enclosure it is necessary to remove the back panel. ***Do not attempt to remove the central panel from the front of the electronics enclosure.***

1. While supporting the back panel, remove the 16 sheet metal screws and flat washers that secure it to the enclosure.
2. Remove the back panel.
3. Installation is the reverse of removal. When reinstalling the back panel, do not over tighten the screws, as this will over compress the gasket.

Removing the Electronics Enclosure from the Refrigerator

(See Figure 11.)

1. Turn the sampler off and disconnect it from power.
2. Disconnect the intake hose from the sampler.
3. Disconnect any other wiring (flow input, alarms, etc.) from the sampler.
4. Open the refrigerator door and remove the sample container.
5. Remove the bottle full sensor from the pinch tubing. Disconnect the two wires from the bottle full sensor's probes by grasping the female crimp connectors on the wires and pulling them off the probes.
6. Open the door on the electronics enclosure and pull the pinch tubing and bottle full sensor cable up through the rubber step grommet on the bottom of the enclosure and remove the grommet.
7. Remove the back panel.
8. The electronics enclosure has two mounting bars underneath it. They are attached to the top of the refrigerator along with the electronics enclosure at six locations. Four of the locations are accessed from inside of the front of the electronics enclosure. The two remaining locations are in the inside of the back of the enclosure (which is why the back panel must be removed). Remove the six screws, lock washers and washers from the refrigerator.

9. Carefully lift the electronics enclosure off of the refrigerator. Be careful not to damage the gaskets on the top of the refrigerator mounted around the holes that the pinch tube is routed through.
10. Put the six screws, lock washers and washers back through the mounting bars and into the holes in the refrigerator top. Cover the holes in the refrigerator top to prevent dirt or moisture from collecting inside.
11. Re-install the back cover on the electronics enclosure.

Installing the Electronics Enclosure on the Refrigerator

(See Figure 11.)

1. Remove the six screws, lock washers and washers from the holes in the top of the refrigerator.
2. Remove the back panel from the electronics enclosure.
3. With the mounting bars positioned over the mounting holes in the refrigerator, carefully position the electronics enclosure on top of the refrigerator. Adjust the positions of the enclosure and mounting bars so that their holes line up with the holes in the refrigerator top.
4. Install the six screws, lock washers and washers through the mounting bars and into the holes in the top of the refrigerator.
5. Open the door to the electronics enclosure. Insert the pinch tubing and bottle full sensor cables through their respective stepped grommets. Route the pinch tubing and bottle full sensor cables through the holes in the bottom of the enclosure and top of the refrigerator. Install the stepped grommets into the holes in the bottom of the enclosure with the small hole that the bottle full cable goes through oriented towards the back.
6. Open the refrigerator door. Make sure that the pinch tubing is not kinked. Connect the bottle full sensors to the cables by pushing the female crimp connectors firmly onto the short ends of the sensor's probes.
7. Run the pinch tubing through the center hole in the bottle full sensors.
8. Position the sample collection containers underneath the pinch tubing, and adjust the height of the bottle full sensors on the pinch tubing by grasping the tubing and then sliding the sensor up or down as required.
9. Connect the sampler intake hoses, any other external wiring (flow, alarms, etc.) and power to the sampler.
10. Re-install the back panel.

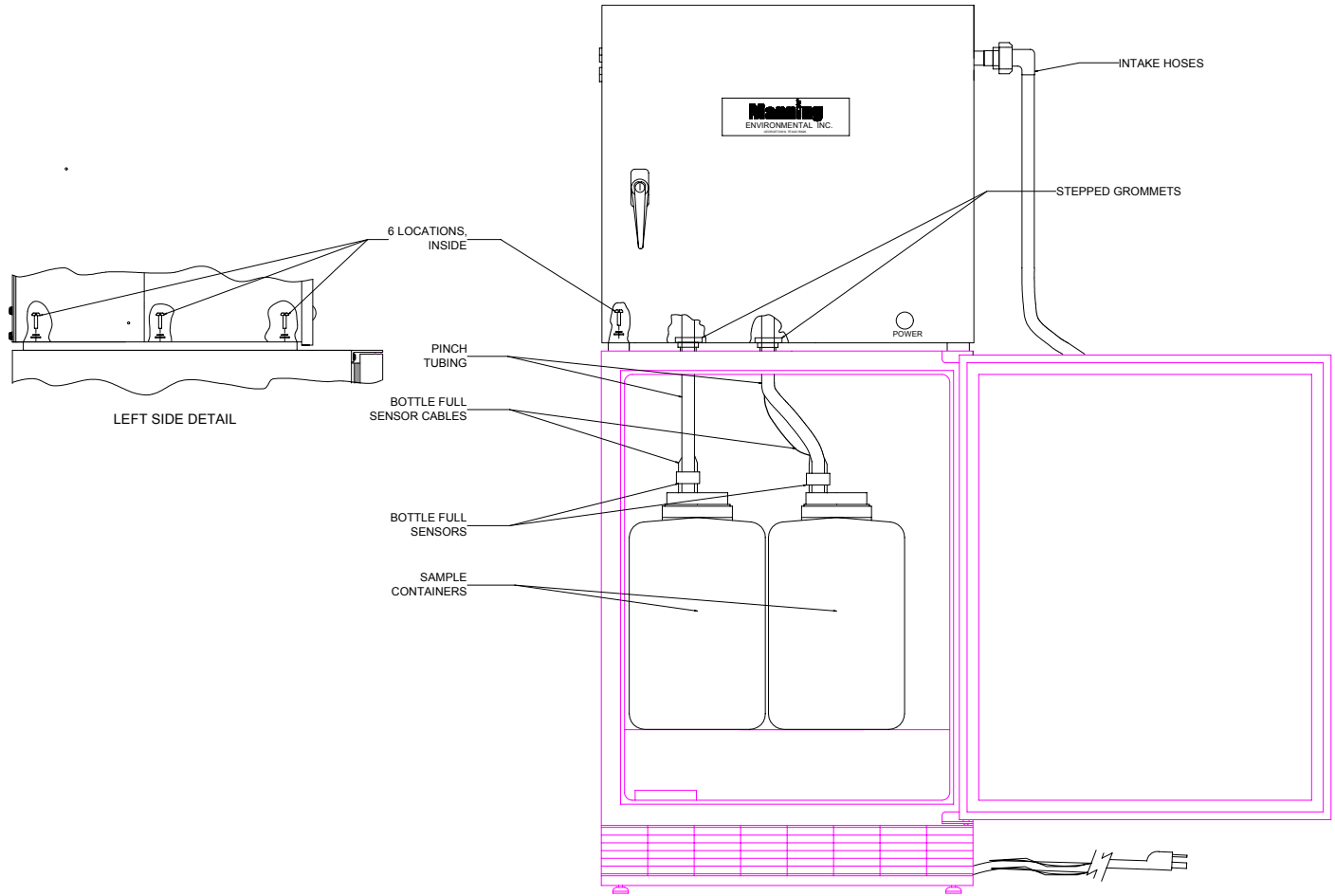

Figure 11. Model S-5200 Sampler Installation With Refrigerator

TROUBLESHOOTING

Troubleshooting instructions are based on a logical sequence of events leading to a malfunction. If problems occur, look for the simplest solution first. Is power connected? Are any connections loose or wires broken? Review the problem, review normal operating procedures, and then check one possibility at a time starting with the easiest to verify. If you continue to have a malfunction, call the Manning Environmental, Inc. Service Department at 1-800-863-9337. We can often assist you over the phone. We can also advise you on whether certain repairs are best done in the field or at our facilities.

Wiring Diagram

A Wiring Diagram for the S-5200 sampler is located at the back of this manual to assist in troubleshooting.

Trouble	Probable Cause	Remedy
Nothing Works	1) Loose Connections 2) Circuit Breaker Tripped 3) Controller Problem	1) Tighten connections 2) Reset Breaker, check for shorts 3) Repair/Replace Controller
Weak Draw	1) Air Leak 2) Pinched intake hose 3) Clogging	1) Be sure that the wing nuts on the top of the chamber top are tight. Check the tubing and fittings for leaks. Check the seals in the measuring chamber. Replace defective parts. 2) Unpinch the hose. Replace the tube if it was damaged. 3) Clean hose and lines
Short samples a) Sample spurts into intermittently, triggering fill sensor with approximately 1/4 sample. b) See Weak Draw	Intake hose drawing air. (Intake not completely submerged)	Position the strainer to avoid taking air into the line

Trouble	Probable Cause	Remedy
Sample drains slowly or not at all from the chamber to the bottles.	1) Inoperative pinch solenoid. 2) Controller Failure.	1) Check pinch solenoid for clogging and proper operation during a manual test cycle. 2) Replace controller
Chamber overfilling, cycling double at fill.	Bottle Full Sensor Inoperative.	Replace Bottle Full Sensor.
Compressor just hums.	Compressor Failure.	Replace Compressor.
Compressor runs but there is no purge or sample taken.	1) Clogged Hose 2) Pinch valve not closing. 3) Controller not giving signal. 4) Leaks	1) Clean Hose. 2) Check the voltage at the solenoid, if 110 volt AC; then the pinch valve needs to be replaced. If not, then the controller needs to be repaired or replaced. 3) With an AC voltmeter, check for 110 volts at the solenoid valve. If no voltage, replace the controller. 4) With the chamber top off, check to see if compressed air is coming through the holes at the top of the post. If not, the compressor is the problem. If air is getting to the chamber top, then the pinch valve is not closing. Repair or replace the pinch valve.
Sampler will not start cycle.	Pressure Switch Stop Activated.	Set dial to OFF then back to TIME, FLOW, or MANUAL CYCLE.

Trouble	Probable Cause	Remedy
Runs and appears to constantly purge.	Pressure Switch failed	Check the pressure switch by following the directions on page 25. If the pressure switch has failed, replace it
Solenoid Valve Chatters.	Solenoid valve in first stage of failure.	Replace solenoid valve, DO NOT WAIT FOR COMPLETE FAILURE!
Sampler works part of the time only.	Compressor Component failure.	Replace controller or both PC boards.

Checking the Differential Pressure Switch

Pressure switch failure can have serious consequences so it is important to replace the switch as soon as possible when it begins to fail.

The pressure switch will fail in one of two ways. It can short, in which case the sampler will switch from purge to draw to measure very quickly (the controller gets a chamber full signal from the shorted pressure switch as soon as it goes into the draw portion of the sample cycle), and no sample will be taken. It can also remain open, in which case the chamber fills completely to the top, and the sampler controller never receives a chamber full signal. The sampler will draw for the entire draw time (either 30 or 90 seconds), and then re-try to take the sample, just as if no fluid was drawn. A float ball located on the chamber top below the air line is designed to prevent fluid from being sucked into the air lines if the chamber overfills in most cases.

Caution: If your pressure switch fails completely, water can flow up to the very top of the chamber and into the compressor, resulting in expensive repairs.

To check the pressure switch follow these instructions.

1. Disconnect the wires leading to the pressure switch.
2. Set the Function Switch to MANUAL-CYCLE. During the draw cycle, touch the wires together before the chamber fills completely. **Do not let the chamber fill completely.** If the draw stops and the measure (purge) begins, replace the pressure switch. If the draw does not stop, immediately turn the Function Switch to Off. Check wiring to pressure switch and controller circuit boards.
3. Call the Manning Service Department (800-863-9337) if you need assistance.

Checking the Pinch Solenoid

The pinch solenoid assemblies, located underneath the measuring chambers and mounted to the bracket, seal off the chamber bases during the purge, draw, and measure portions of the sample cycle. If they become

noisy during operation, this could be a sign of impending failure. To check the pinch solenoid, follow these instructions.

1. Check to see if the pinch tubing is centered in the pinch assembly. If the tubing is cocked to one side, this will cause the solenoid to hum.
2. Verify that the solenoid is securely mounted to the bracket.
3. Inspect the springs and other pinch assembly components for wear.
4. Disconnect the two wires from the side of the pinch solenoid. Using an Ohmmeter, test the resistance of the solenoid coil. A good solenoid will measure approximately 6.5 Ohms. If the resistance is much less than this, the coil is drawing excessive current and should be replaced. If the current draw of the pinch solenoid is allowed to increase too much, damage to the power board will result.

HOW TO RETURN EQUIPMENT

Call or write the Manning Environmental Service Department before returning any equipment for repair. Many problems can be diagnosed and resolved over the telephone. Manning will issue a Return Material Authorization (RMA) number if it is deemed necessary that the equipment be returned for repair.

If you do need to return equipment, follow these guidelines:

- ◆ Pack equipment carefully, preferably in the original carton.
- ◆ Enclose specific information about the problem.
- ◆ Enclose a contact name and phone number in case our Factory Service Department needs additional information.
- ◆ Enclose a purchase order authorizing repairs.
- ◆ Ship the equipment to the address below. Our Receiving Department will not accept collect shipments.

Note: Equipment being returned for repairs should be reasonably clean. Due to the health risks posed by exposure to some fluids that may be sampled, Manning reserves the right to charge additional labor fees if cleaning of the sampler equipment is necessary to safely repair it.

The Service Department phone number is (800) 863-9337. The Service Department will notify you of the type of repair needed and an estimate of the cost of the repairs. Manning will ask for authorization before proceeding.

Address For Repairs:

Manning Environmental, Inc.
RMA # _____
1968 South Austin Avenue, Suite 101
Georgetown, Texas 78626

Options, Accessories, & Spare Parts

Alarm Board Option

The Alarm Board Option gives the sampler the ability to provide 5A-rated relay contacts (up to 32VDC, 120/240VAC) that are closed when certain events (alarms) occur. The three alarms possible are Missed Sample (Line Plugged), Bottle Full and Sample Cycle. The S-5200 sampler uses two alarm boards, mounted in front of the Power Boards on the inside of the sampler enclosure using standoffs. The Alarm Board is connected to the Power Board using a ribbon cable assembly. The Logic Board's ribbon cable is also connected to the Alarm Board.

The relay contacts can be used to illuminate a lamp on the front door of the sampler enclosure, activate an audio alarm located in the sampler housing, or trigger an external device supplied by the operator. Depending upon the configuration ordered, the board may provide relay contacts for one or more of the events listed above.

This Alarm Board uses three double-pole, single throw relays that provide two sets on normally open contacts for each event/alarm. The board has a 12-position terminal board for making connections to the lamps or other external devices. It also has two 14-pin DIP sockets (J1 and J2) connected in parallel. These two sockets allow the board to interconnect with the Logic and Power boards. See Figure 12.

Alarm Functions

MISSED SAMPLE (LINE PLUGGED):

The missed sample (line plugged) alarm circuit provides a relay contact closure when the sampler fails to draw a full sample after the normal sample cycle and retry cycle (the pressure switch is not actuated). The relay will remain closed until reset by a subsequent successful sample cycle, or power to the sampler is turned off. If the controller Function switch is set to the OFF position during a sample cycle, the Missed Sample relay energizes.

BOTTLE FULL:

The Bottle Full alarm circuit is activated when the sample bottle is filled (fluid is making contact with both probes of the Bottle Full Sensor).

SAMPLE CYCLE:

The Sample Cycle alarm circuit is activated when the sampler is taking a sample (the compressor is on).

By wiring in parallel the second set of relay contacts for the Bottle Full and Missed Sample alarms, a single "Sampler Trouble" output is created which can be used to alert operators to check the sampler. If additional relay contacts are required, the alarm board relays can be used to actuate customer-provided relays. See Figure 13 for typical alarm wiring.

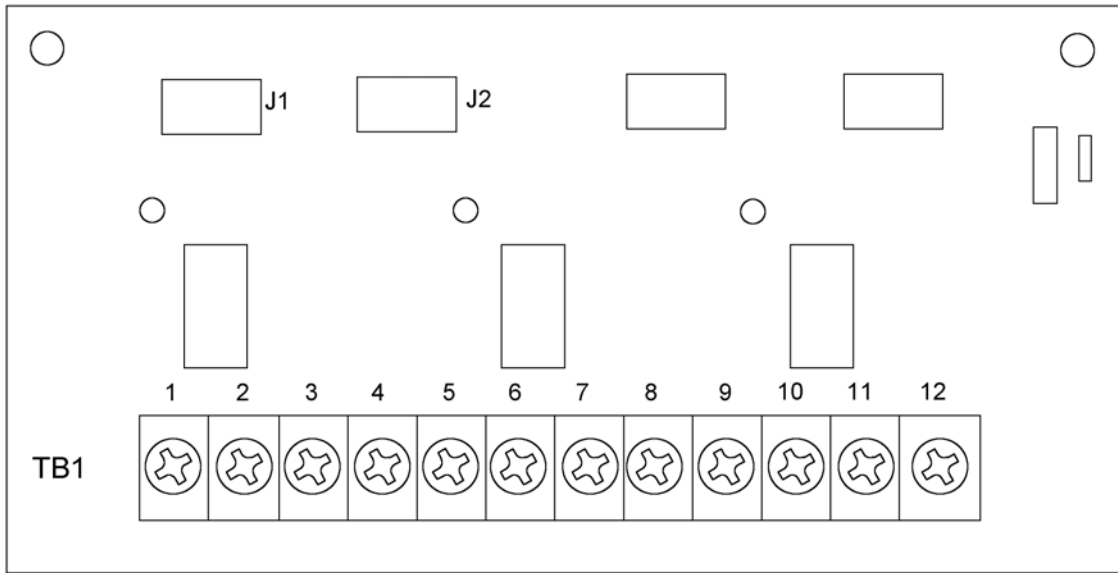

Output connections: Bottle Full- TB1-1 & TB1-2 and TB1-3 & TB1-4; Sample Cycle- TB1-5 & TB1-6 and TB1-7 & TB1-8; Missed Sample- TB1-9 & TB1-10 and TB1-11 & TB1-12

Figure 12. Alarm Board

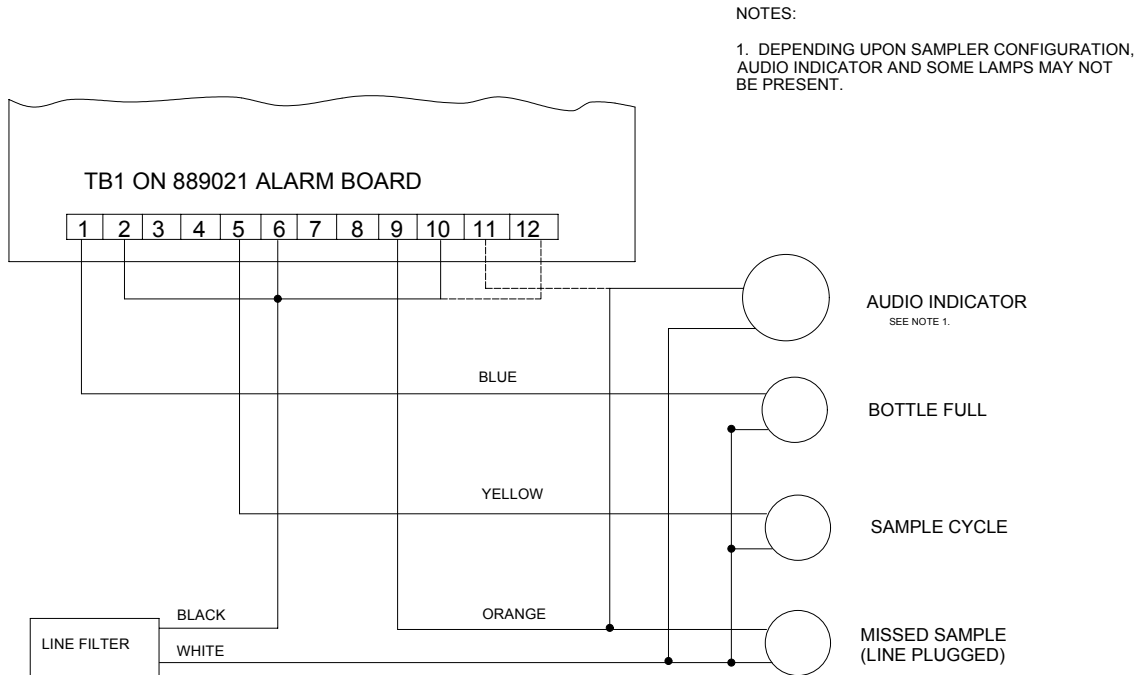

Figure 13. Typical Alarm Board Wiring

Totalizer Option

The totalizer accepts a 4-20mA analog signal that is representative of flow and provides a momentary contact closure output to the sampler controller that will trigger a sample when the sampler is in the FLOW mode. The S-5200 sampler may be equipped with either one or two totalizers, which are mounted on the inside of the front door of the electronics enclosure. If the sample is equipped with only one totalizer, it is connected to Chamber #1. See Figure 14.

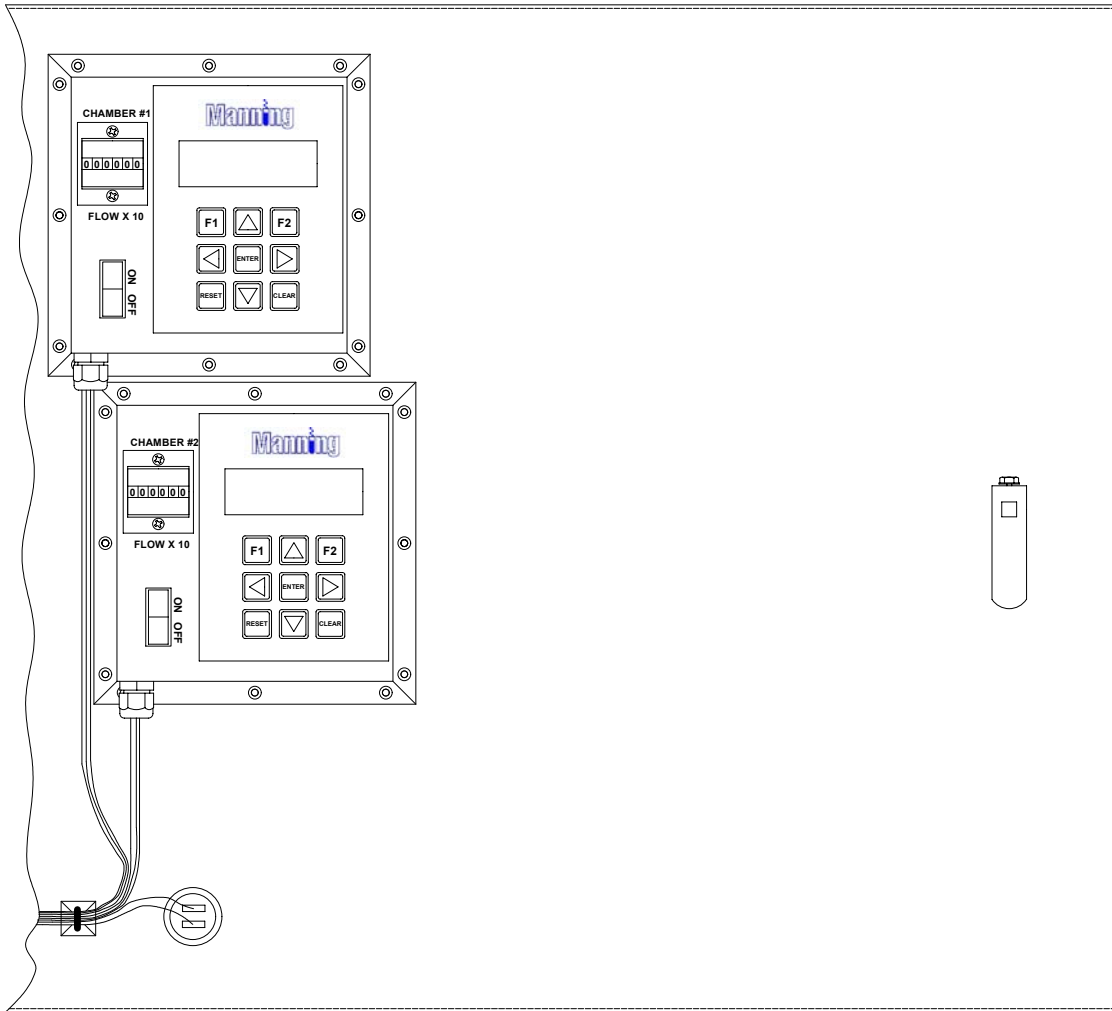

Figure 14. Dual Totalizers Mounted on the S-5200 Electronics Enclosure Front Door

The totalizer uses a microprocessor with a 10-bit analog-to-digital converter. The microprocessor contains FLASH memory that holds the totalizer program. The operator inputs the minimum and maximum flow rates, along with the accumulated flow value that will trigger a sample. When running, the totalizer reads the analog signal and accumulates the amount of flow. When the accumulated flow reaches the trigger level, a momentary contact closure is sent to the sampler controller to trigger a sample. A 6-digit counter is incremented at ten times the maximum flow level.

Terminal Board 1 (TB1) located on the back of the sampler central panel inside the electronics enclosure is where the wires connecting the 4-20mA signal (such as a flowmeter) are connected. See figure15 below.

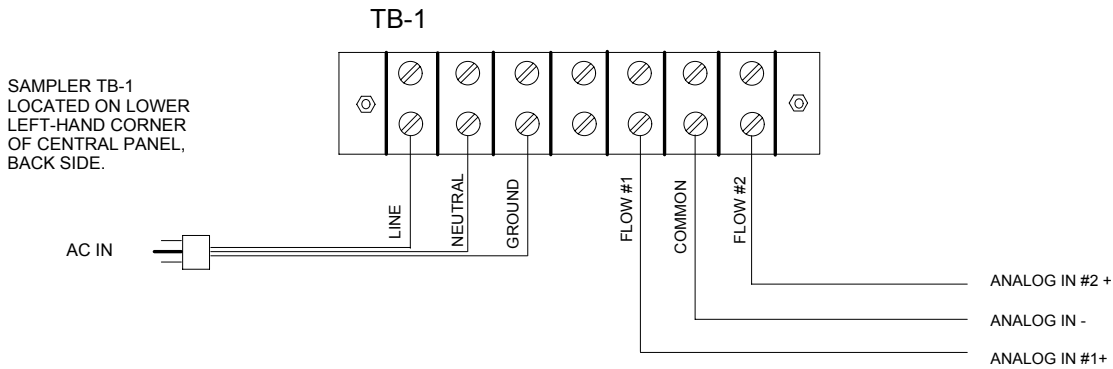

Figure 15. S-5200 Analog (4-20mA) Connections

The sampler comes equipped with two pigtails one for each chamber, which are connected to TB-1 and terminate outside of the sampler on the right side above the power cord. These can be used to make the connections to the current source, or the back panel can be removed and connections can be made to TB-1 directly. On S-5200's with dual totalizers, each totalizer must have a separate 4-20mA source because they share a common ground on the sampler.

The totalizer enclosure contains the totalizer circuit board, a 4 line by 20 character Liquid-Crystal Display (LCD) with a backlight, a power on/off switch, a 6-digit non-resettable counter, and a keypad. Wiring enters the totalizer through a bulkhead fitting in the lower left hand corner of the enclosure. See Figure 16.

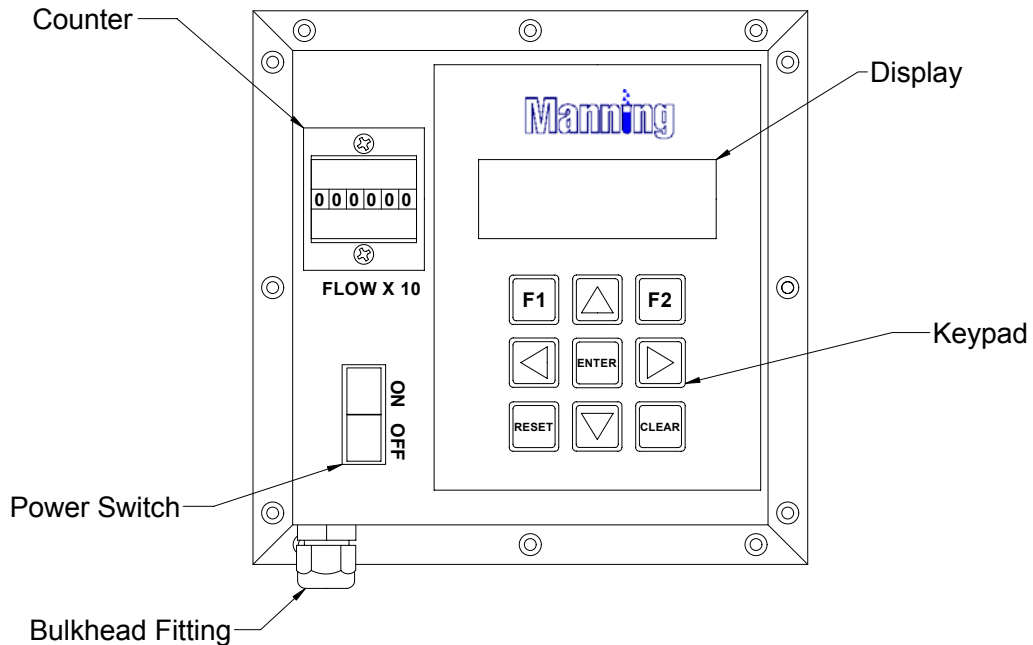

Figure 16. Totalizer Enclosure

The Power Switch controls power to the totalizer. When power is turned on, the totalizer is reset, and any accumulated flow data is lost. Set the sampler function switch to OFF before turning on the totalizer. The 6-digit counter is incremented each time the accumulated flow equals ten times the maximum flow. The display is a 4 line by 20 character LCD with a backlight that provides various information to the operator. The backlight automatically turns off ten seconds after a key is pressed, unless another key is pressed. The Keypad contains nine keys arranged 3 x 3 that are used to operate the totalizer. The keys consist of 4 arrow keys (UP, DOWN, LEFT, and RIGHT), ENTER, RESET, CLEAR, and two function keys, F1 and F2.

The totalizer has four operating modes- Calibrate, Setup, Run, and Diagnostic. First, the totalizer must be calibrated so that it can properly read the 4-20mA signal. Then, it is setup by the operator entering the minimum, maximum, and trigger flow values. After these two steps are completed, the totalizer enters the run mode, where it reads and accumulates the flow, triggers samples, and increments the counter. The diagnostic mode allows the operator to perform various tests to insure that the totalizer is operating correctly.

When the totalizer is turned on, it briefly displays a message with the software revision. After that, the totalizer checks to see if it has been calibrated, if not, it enters Calibration Mode. If calibration has been completed, then it checks for valid setup data. If there is no valid setup data, Setup Mode is entered. If setup data has been entered, the totalizer enters Run Mode. Below are detailed descriptions of the totalizer's modes:

Calibrate Mode.

The totalizer is shipped with a factory-calibration applied. If it is necessary to recalibrate the totalizer for any reason, a milliamp calibrator with an accuracy of $\pm 0.5\text{mA}$ or better is required. The calibrate mode can be entered by holding down the F2 key and pressing the F1 key while the totalizer is in Run mode. The display then reads:

```
CALIBRATION MODE  
SET ALG IN TO 4mA  
AND PRESS ENTER
```

Connect the milliamp calibrator up the appropriate FLOW terminals on TB1 (or the short pigtail coming out of the side of the sampler electronics enclosure). Set the calibrator to 4mA and press the ENTER key on the totalizer keypad. The display changes to CALIBRATING..

After five seconds, the display changes to

```
CALIBRATION MODE  
SET ALG IN TO 20mA  
AND PRESS ENTER
```

Set the calibrator to 20mA and press the ENTER key. Again, the display changes to CALIBRATING.. After five seconds, the totalizer will automatically enter the Setup mode if the calibration was valid. If the calibration was not valid, the LCD will display INVALID CALIBRATION DETECTED RECALIBRATION IS NECESSARY for seven seconds and then return to the first calibration display.

The totalizer looks at the difference between the 4mA and 20mA values that were measured during the calibration, and if there was not enough difference between them, then the calibration is considered invalid. The totalizer stores the calibration information in non-volatile FLASH memory

Setup Mode.

In Setup Mode, the operator enters the minimum and maximum flow rates, along with the sample trigger level. Minimum and maximum flow rates are entered in *units per minute* (for example, if the flow transmitter’s output is in Gallons per Day, then dividing the value by 1440 gives you the Gallons per Minute value) The minimum flow rate is what the rate of flow is when the current input to the totalizer is 4mA (in most cases, this will be 0, but it could be different depending upon how the flow transmitter is setup). The maximum flow rate is what the rate of flow is when the current input to the totalizer is 20mA. The trigger level is the amount of accumulated flow that will trigger a sample.

The Setup Mode is automatically entered after a calibration is completed. It may also be entered from the Run Mode by pressing the F1 key. The first display is:

ENTER MIN FLOW
IN UNITS PER MINUTE:

000000000

A minimum flow rate between 0 and 999,999,999 can be entered. A blinking cursor on the LCD indicates the current position to be modified (the totalizer defaults to the 4th or 1000-units position). Use the right and left arrow keys to move the cursor over the digit to be changed. The up and down arrow keys are used to change the value (from 0 to 9) of the digit selected. Pressing the CLEAR key will clear all entered data and return the cursor to the default position. After the minimum flow rate value has been entered correctly by using the four arrow keys, press the ENTER key. The display then changes to:

ENTER MAX FLOW
IN UNITS PER MINUTE:

000000000

Enter the maximum flow rate (0 to 999,999,999) the same way as the minimum flow rate was entered using the four arrow keys. After the maximum flow value has been entered correctly, press the ENTER key. The display then changes to:

ENTER TRIGGER
IN UNITS:

000000000

Enter the trigger level (0 to 999,999,999) the same was as the minimum and maximum flow rates were entered using the four arrow keys. The trigger level must be greater than the maximum flow rate. After the trigger level has been entered correctly, press the ENTER key. The totalizer stores the setup

information in non-volatile FLASH memory. After setup is complete, the totalizer automatically enters the Run Mode.

Run Mode.

The totalizer will automatically enter the Run Mode when it is turned on if there is valid calibration and setup data stored in memory. In Run Mode, the totalizer reads the value of the input flow signal (4-20mA) once each minute and converts it to an amount of flow based on the stored setup and calibration information. This value is accumulated in temporary memory in two locations- one for triggering a sample, and one for incrementing the counter.

When the accumulated value in the trigger location reaches or exceeds the trigger level, the totalizer triggers a sample and subtracts the trigger value from the accumulated value.

When the accumulated value for incrementing the counter reaches or exceeds ten times the maximum flow, the counter is incremented one digit; and ten times the maximum flow value is subtracted from this accumulated value.

During Run Mode, the LCD will switch between three different screens while accumulating flow (Note: the values displayed are examples):

```
CURRENT:          1000
ACCUM. :          800
SAMPLE IN
8000 UNITS
```

In the first screen, the first line indicates the flow amount at the last reading by the totalizer. The second line indicated the current accumulated flow. The third and fourth lines display the amount of flow remaining for the next sample trigger. After five seconds, the display changes to:

```
TRIGGER:          10000
ACCUM. :          800
MIN FLOW:         0
MAX FLOW:         20000
```

The first line displays the trigger level (as entered in the last setup). The second line displays the current accumulated flow. The third and fourth lines display the minimum and maximum flow rates (as entered in the last setup) respectively. After five seconds, the display changes to:

```
TOTAL SAMPLES:
3
```

The second line displays the total number of samples triggered. The totalizer does not store the accumulated flow or total samples in non-volatile memory. Therefore, whenever the totalizer is turned off or reset by pressing the RESET key, this data is cleared.

Whenever a sample is triggered, SAMPLE TRIGGERED is momentarily displayed on the LCD.

Diagnostic Mode.

The diagnostic mode is used to test the operation of the totalizer. To enter the diagnostic mode press the F1 key twice while the sampler is in Run Mode, or once while the sampler is in Setup Mode. When Diagnostic Mode is entered, the display changes to:

```
DIAGNOSTIC MODE  
CURRENT VAL: 5.33  
PRESS UP TO SAMPLE  
DOWN TO ADVANCE CTR
```

The second line of the display shows the value of the input signal in mA. Pressing the up arrow key causes the totalizer to generate a momentary contact closure to the sampler controller to trigger a sample. Pressing the down arrow key will increment the counter.

To exit Diagnostic Mode, press the RESET key.

Flow-Through Cell Option

The S-5200 Sampler is designed for use with non-pressurized fluid sources. In some instances, it is necessary to sample from a pressurized pipe or other source. The Flow-Through Cell (FTC) allows sampling from pressurized sources by relieving the pressure. The FTC operates by opening the stream to the atmosphere, thereby reducing the effective pressure to zero.

In the fall of 2000, Manning changed the design of the FTC. With the old design, the FTC was mounted on the side of the sampler with a bracket. In the current design, the FTC may be mounted wherever it is practical, normally close to the pressurized source.

Both versions of the FTC operate the same way. See Figures 17 and 18.

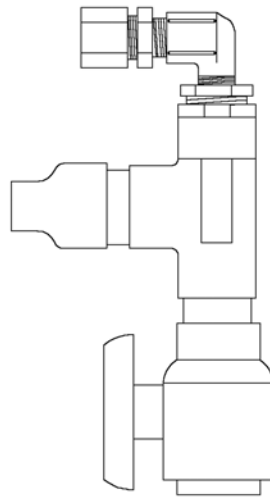

Figure 17. Flow-Through Cell

Operation

Refer to Figure 18. The pressurized source is connected to the ball valve on the inlet of the FTC. The ball valve is used to adjust the flow to not more than 50 GPM at 50-PSI maximum. It also allows fluid to the FTC to be shut off for cleaning and maintenance.

Fluid then enters the clear PVC tee and flows out of the FTC to an open-air drain. The third opening on the clear PVC tee is attached to the sampler intake hose using a bushing and fittings. An intake tube attached to the bushing allows the sampler to draw fluid from and purge fluid back to the FTC. The bushing can be easily removed for cleaning.

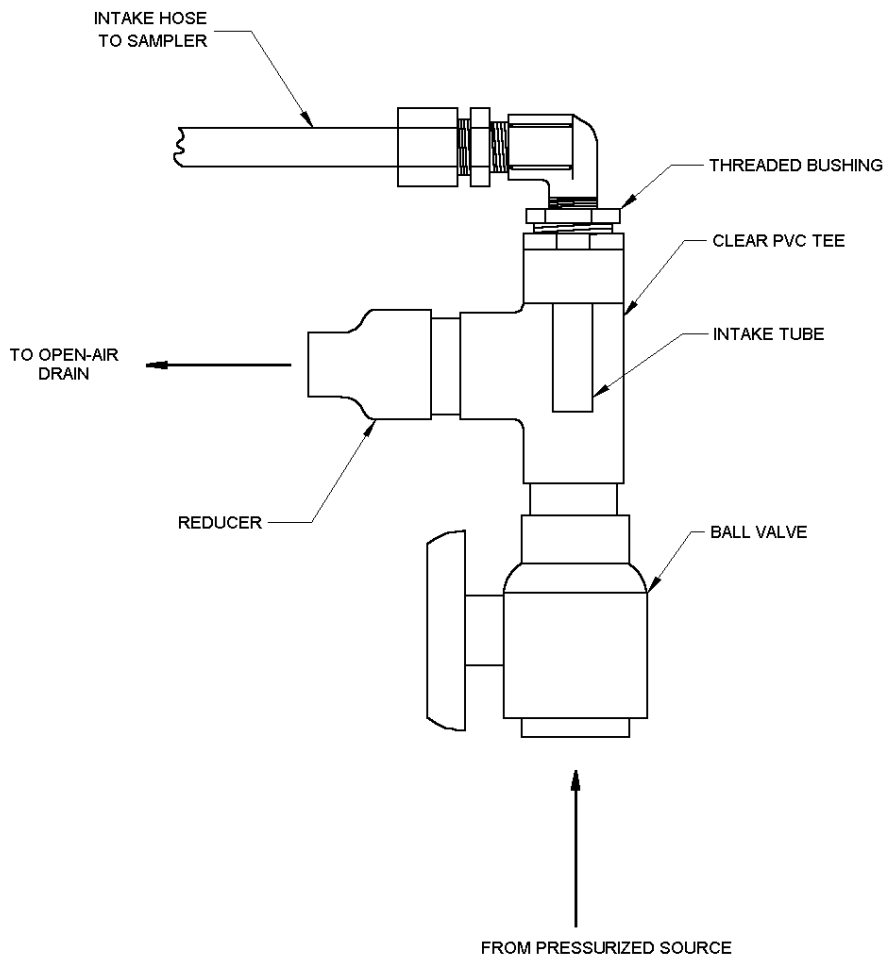

Figure 18. Flow-Through Cell Operation

Installation

General

Appropriate piping to the FTC is required so that the pressurized source and open-air drain are available. The sampler must be located higher than the FTC, and the intake line to the sampler must be routed so that it does not have any dips where fluid could collect.

It is important that the pipe from the FTC outlet to the drain does not have any reductions in it. Any reductions or excessive elbows will increase the pressure at the intake point for the sampler.

The FTC is designed to operate with a flow of not more than 50 GPM at 50-PSI. In instances where the flow cannot be reduced sufficiently with the manual ball valve, an additional pressure reduction valve must be installed before the FTC,

Normally, flow through the FTC is continuous. In some applications it is desirable to only have flow through the FTC during a sample cycle. To accomplish this an electrically actuated ball valve may be installed close to the pressurized source. The valve is opened only during the sample cycle. See Figure 19.

Most electrically actuated ball valves require a relay to control them. This relay and the sampler can be controlled by a PLC or other control circuitry. If the Alarm Option is installed on the S-5000 Sampler, the SAMPLE CYCLE relay can be used to control the ball valve relay. See the Alarm Option section for more information on the SAMPLE CYCLE relay.

1. The FTC is shipped with the manual ball valve and reducer loose. The 1-1/2" to 3/4" reducer pipe may be discarded if not needed. Attach the manual ball valve to the pressurized line with 3/4" pipe.
2. Attach the other end of the ball valve to the inlet of the clear PVC tee using 1-1/2" pipe. A 4" piece of 1-1/2" pipe is supplied to attach the other end of the manual ball valve to the clear PVC Tee. A longer piece of pipe may be substituted if required.
3. Connect the outlet of the clear PVC Tee (through the reducer, if used) to the open-air drain using appropriate piping.
4. Attach the sampler intake hose to the FTC using the compression fitting.
5. Adjust the ball valve so that flow does not exceed 50 GPM at 50-PSI maximum.
6. The FTC may be left freestanding or may require mounting to a bracket or brace depending upon location.

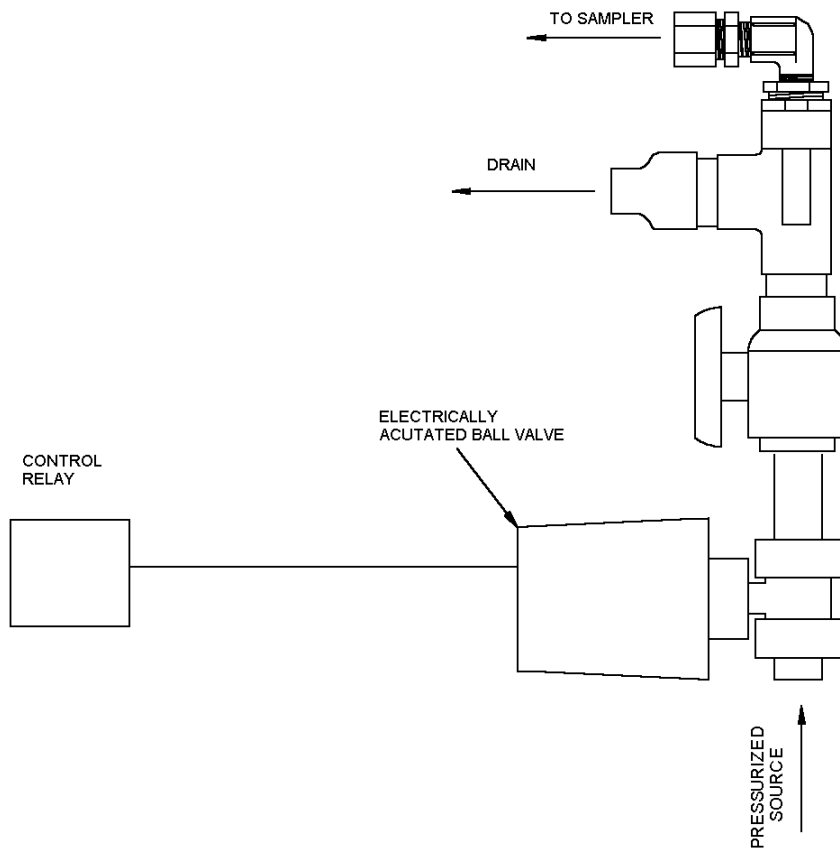

Figure 19. Flow-Through Cell with Electrically Actuated Ball Valve

SPARE PARTS & ACCESSORIES

The following is a list of spare parts available from the Manning Environmental Parts Depart. Contact the Parts Department at 1-800-863-9337.

PINCH/CHAMBER SUPPORT BRACKET PARTS

Part Number	Description	U/I	Qty
MS889228	Pinch Valve Subassembly, Twin	EA	1
.MS889423	Pinch Solenoid, 115VAC	EA	2
.MS548015	Pinch Spring	EA	4
.MS763012	Retaining Ring, "E"	EA	4
.MS579404	Pull Bar	EA	2
.MS579403	Pinch Bar	EA	2
.MS911410	Screw, Drive	EA	4
.MS912137	Wellnut	EA	4
.MS525101	Standoff, Pinch Bar	EA	4
.MS579553	Pad, Bounce	EA	2
MS579401	Rod, Chamber Hold-down	EA	4

MECHANICAL AND ELECTRICAL PARTS

Part Number	Description	U/I	Qty
MS6754154	Compressor, Air, 115VAC 60Hz	EA	2
MS565861	Valve, Air, 4-Way, 115VAC 60Hz	EA	2
MS640522	Transformer, Low Voltage	EA	2
MS675416	Power Line Filter	EA	2
MS6385741	Circuit Breaker, 10A, Rectangular, Rocker Switch	EA	1
MS552097	Fitting, Air, Quick-Disconnect, Straight	EA	2
MS552098	Fitting, Air, Quick-Disconnect, 90° Elbow	EA	10
MS566911	Tubing, Air, Clear	IN	A/R
MS566913	Tubing, Air, Blue	IN	A/R
MS783027	Vapor Capsule	EA	2
MS675427	Indicator Light, Amber, 115VAC	EA	1

ELECTRONIC/CONTROLLER PARTS

Part Number	Description	U/I	Qty
MS889002-2	Logic Board, S-5200	EA	2
MS889621-4	Power Board	EA	2
MS886311	Alarm Board (Optional)	EA	A/R
MS488004	Knob, Logic Board	EA	4
MS810035	Ribbon Cable, Alarm Board to Power Board (Optional)	EA	A/R
MS889025	Totalizer Assembly (Optional)	EA	A/R

MEASURING CHAMBER ASSEMBLY PARTS

Part Number	Description	U/I	Qty
MS579402	Measuring Chamber	EA	2
MS889006	Chamber Top Assembly	EA	2
MS889050	Chamber Base	EA	2
MS542180	O-ring, Chamber Top and Base	EA	4
MS542186	O-ring, Chamber Top Slotted Tube	EA	2
MS542201	O-ring, Chamber Top Inlet	EA	2
MS638542	Pressure Switch Assembly	EA	2
MS566900	Tubing, Pressure Switch	IN	16
MS579411	Support Ring, Chamber Top	EA	2
MS566899	Pinch/discharge tubing	IN	A/R
MS579406	Clamp, Pinch Tube to Chamber Base	EA	2
MS912136	Wingnut	EA	4

INTAKE HOSES AND STRAINER

Part Number	Description	U/I	Qty
MS552018	Strainer, 5/8" Intake, PVC	EA	A/R
MS566901	Hose, 5/8" ID, Nylon-Reinforced, PVC, Bulk	FT	A/R
MS566918	Hose, 5/8" ID, Clear PVC, Bulk	FT	A/R
MS889811	Intake hose, 10' Clear PVC with strainer	EA	A/R
MS889812	Intake hose, 25' Clear PVC with strainer	EA	A/R
MS889038	Intake hose, 10' Nylon-reinforce PVC with strainer	EA	A/R
MS889008	Intake hose, 25', Nylon-reinforced PVC with strainer	EA	A/R
MS889484	Intake hose, 100' Nylon-reinforced PVC without strainer	EA	A/R
MS889530	Hose, short, intake, S-5200 Chamber #1	EA	1
MS889531	Hose, short, intake, S-5200 Chamber #2	EA	1
MS889808	Intake hose, 10' Clear PVC without strainer	EA	A/R
MS889054	Intake hose, 100' Nylon-reinforced PVC with strainer	EA	A/R
MS889851	Intake hose, 25' Clear PVC without strainer	EA	A/R
MS889382	Intake hose, 50' Nylon-reinforced PVC with strainer	EA	A/R
MS889053	Intake hose, 25' Nylon-reinforced PVC without strainer	EA	A/R

BOTTLES AND RELATED SPARE PARTS

Part Number	Description	U/I	Qty
MS889822	Bottle Full Sensor	EA	2
MS687551	Bottle, 4-Gallon Polyethylene	EA	A/R
MS687547	Bottle, 2.5 Gallon Polyethylene	EA	A/R
MS687535	Bottle, 5 Gallon Rectangular Polyethylene	EA	A/R
MS889715	Bottle, 2.5 Gallon Glass with Teflon-lined Lid	EA	A/R

OTHER PARTS

Part Number	Description	U/I	Qty
MS889497	Refrigerator, S-5200, White Enamel, 115VAC 60Hz	EA	1
MS889498	Refrigerator, S-5200, Stainless Steel, 115VAC 60Hz	EA	1
MS579565	Mounting Bar, Sampler to Refrigerator, S-5200	EA	2
MS889631	Flow-Through Cell, 5/8" Intake (Optional)	EA	A/R

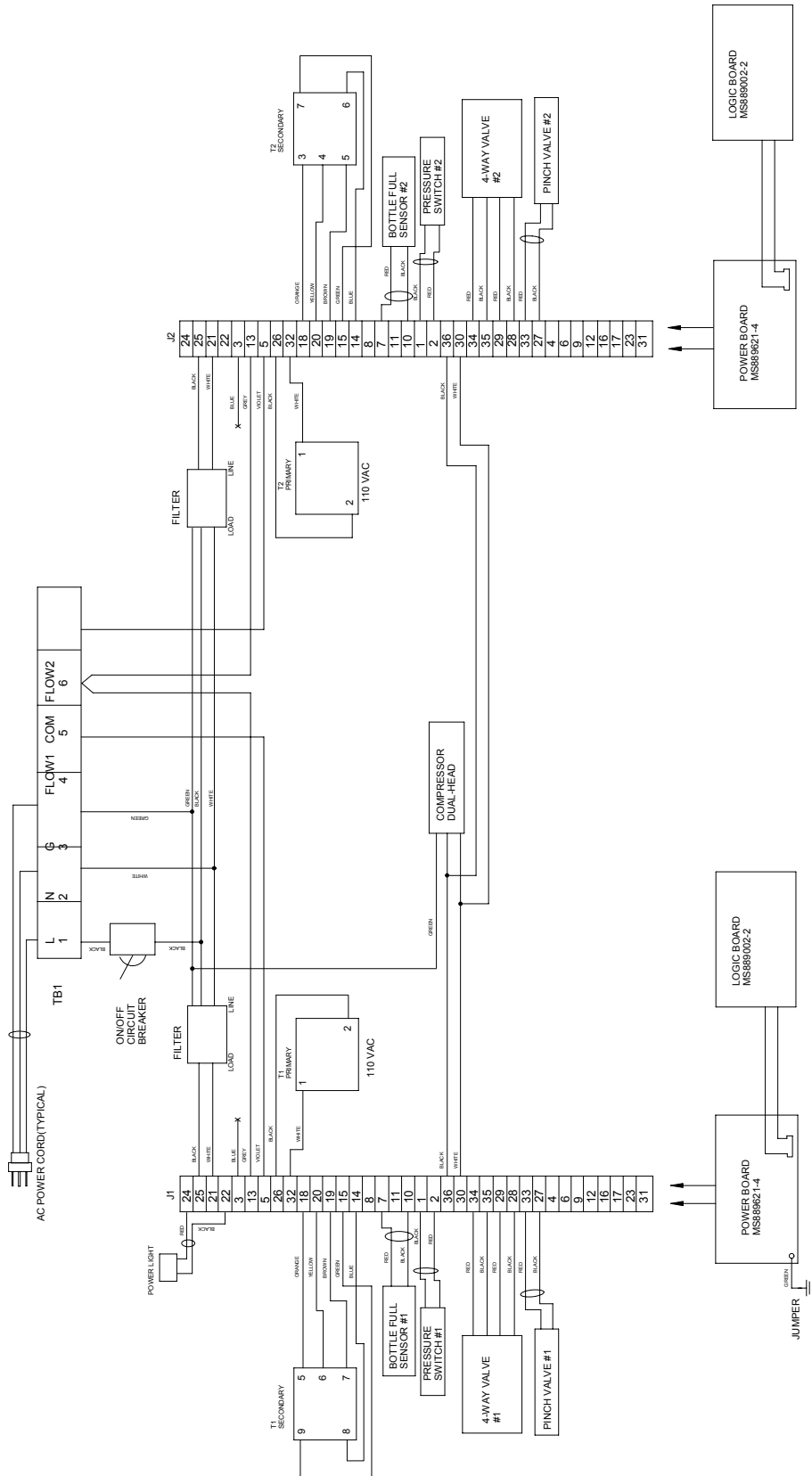

Figure 20. S-5200 Wiring Diagram

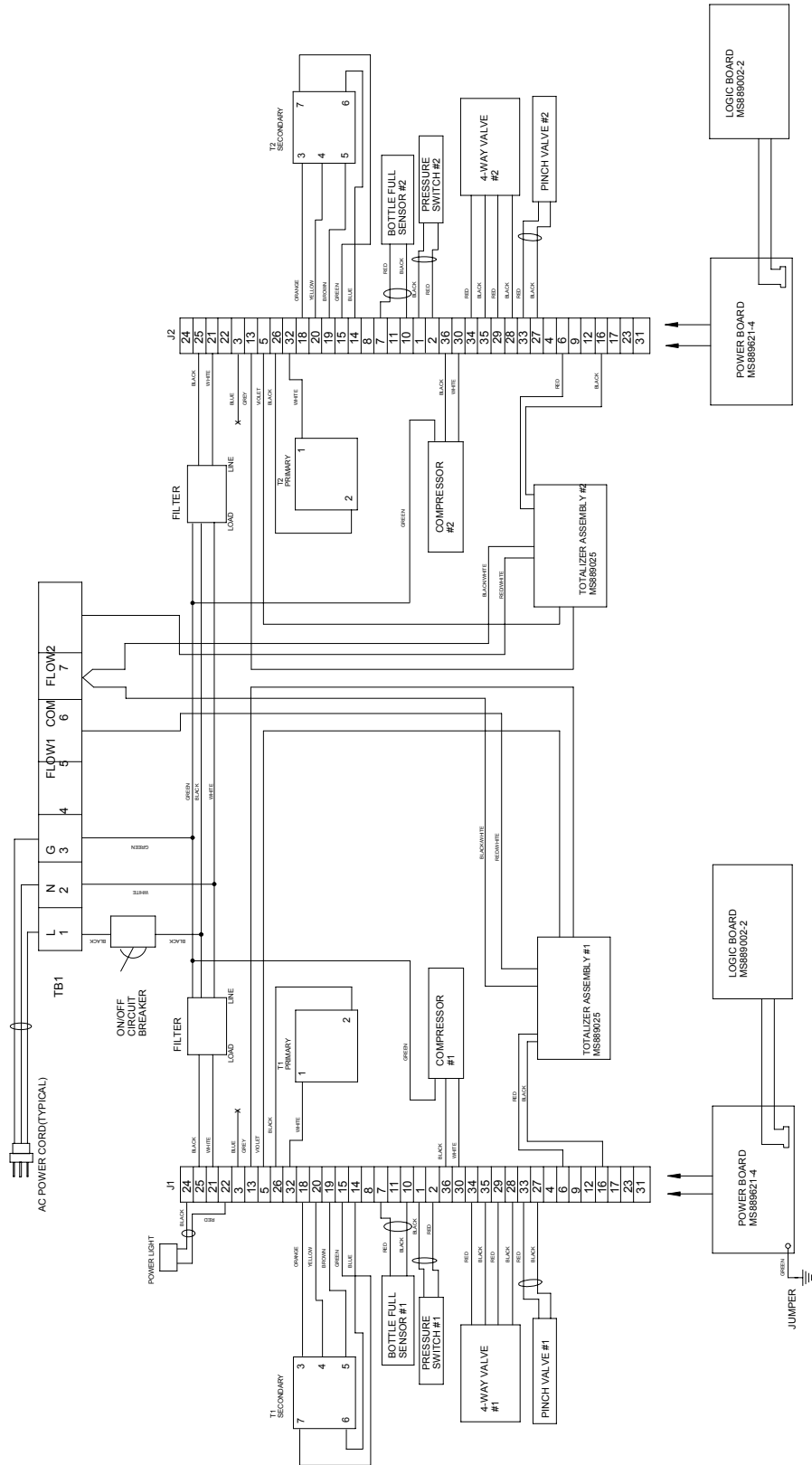

Figure 21. S-5200 Wiring Diagram with Totalizers

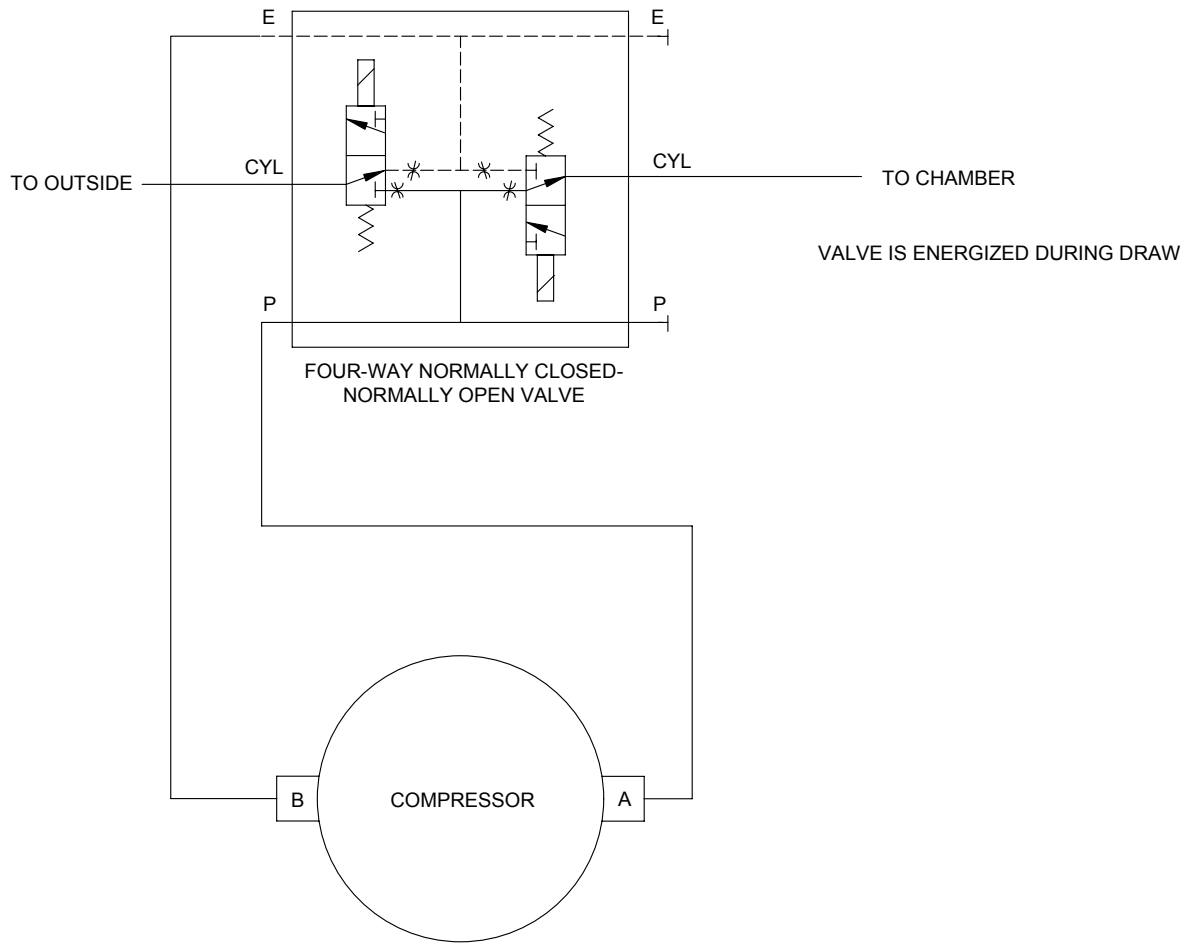

Figure 22. S-5200 Air System Diagram
(Only One Chamber Shown)