

# Operation and Maintenance Manual

## Manning Environmental Sampler Model S-5000



1904 South Austin Avenue Suite 102  
Georgetown, Texas 78626-7808  
Phone: 512-863-9337  
Fax: 512-863-4472  
Copyright 2001

**Manning**  
ENVIRONMENTAL • INC.

“Sampling Today’s Water  
For Tomorrow’s World”

OPERATION AND MAINTENANCE  
of  
MANNING ENVIRONMENTAL, INC.  
  
**MODEL S-5000**  
**STATIONARY COMPOSITE STAMPLER**

Manual Part Number 717659

May 2001

Manning Environmental, Inc.  
1904 South Austin Avenue  
Suite 102  
Georgetown, Texas 78626-7808  
Telephone: 512-863-9337  
Fax: 512-863-4472

Copyright 2001, by Manning Environmental, Inc.

All rights reserved. This work is protected by Copyright and other laws. Copying any aspect of this work is strictly prohibited.

## **Warning!**

**Dangerous electrical voltages are present in this equipment. Turn equipment off and disconnect power prior to servicing. Only qualified personnel should make electrical connections to the equipment**

## **Caution**

**The pinch solenoid assemblies located underneath the measuring chambers close with great force. Do not place your fingers, tools or other items in their path while power is turned on.**

## **Caution**

**Some fluids that are sampled may pose a health risk. Observe proper protective procedures when handling sample containers or any other parts of the equipment that has come in contact with the fluid.**

## **Caution**

**The electronics enclosure and refrigerator are heavy. Observe caution when moving the equipment.**



1904 ♦ SOUTH ♦ AUSTIN ♦ AVENUE ♦ SUITE 102  
GEORGETOWN ♦ TEXAS ♦ 78626-7808  
Phone 1-(512)-863-9337 FAX 1-(512)-863-4472

## LIMITED WARRANTY

### WHAT IS COVERED:

- A. Manning Environmental Inc. warrants its equipment will conform to the written performance specifications, if any, provided to the purchaser as part of Manning Environmental Inc. order acknowledgment or Manning Environmental Inc. written communication.
- B. Manning Environmental Inc. further warrants it will repair or replace, free of charge; any equipment or part that it supplies that is defective (upon review by Manning Environmental Inc. or its authorized agent) in material or workmanship.
- C. This warranty is good for TWELVE (12) MONTHS from date of shipment for all equipment and parts except:
  - a. As otherwise stated in seller's quotation or acknowledgment of order.
  - b. Direct buy-out items, such as computer peripherals, which carry the manufacturer's warranty.
  - c. Repair parts and services that are covered under a separate limited service warranty.
  - d. Refrigerators, which are covered under the refrigerator manufacturers' warranty.

### WHAT IS NOT COVERED:

- A. Transportation charges (warranty is F.O.B. Manning Environmental Inc. factory, Georgetown, Texas).
- B. Repair and/or replacements by misuse, negligence, modification, accident, use of parts not supplied by Manning Environmental Inc., or lack of required maintenance.
- C. Fuses, Batteries, Differential Pressure Switches, Sample Containers, Hoses and Tubing.
- D. INCIDENTAL OR CONSEQUENTIAL DAMAGES SUCH AS TELEPHONE CALLS, LOSS OF TIME, INCONVENIENCE, OR COMMERCIAL LOSS.
- E. ANY IMPLIED WARRANTY (THAT WHICH IS NOT EXPRESSED) INCLUDING THOSE OF MERCHANTABILITY OR FITNESS FOR A PARTICULAR PURPOSE.
- F. THIS IS THE ONLY EXPRESSED WARRANTY AUTHORIZED BY MANNING ENVIRONMENTAL INC

**OWNER'S RESPONSIBILITIES:**

- A. To obtain warranty service, you are responsible for delivery of the equipment/part to Manning Environmental Inc. factory, Georgetown, Texas. A Return Authorization Number (RMA) must be obtained from Manning Environmental Inc. prior to returning the equipment. (Manning Environmental Inc. will provide personnel for on-site warranty service provided the owner agrees to pay for all travel time, all nonproductive time of Manning Environmental Inc. personnel while on-site caused in whole or in part by owner, and for all transportation, lodging and per diem cost for service personnel at Manning Environmental Inc. prevailing rate. On-site productive labor and parts will be provided at no expense to the owner.)
- B. Equipment returned to Manning Environmental Inc. for warranty repair must be shipped prepaid to the following address:

Manning Environmental Inc.  
RMA \_\_\_\_\_  
1904 South Austin Avenue Suite 102  
Georgetown, Texas 78626-7808

- C. You are responsible for properly operating, maintaining, and caring for your Manning Environmental Inc. equipment in accordance with the instructions contained in the Owner's Manual.
- D. You are responsible for keeping maintenance records, if required by the Owners Manual, since in some instances, it may be necessary for you to show that required maintenance/service has been performed in order to be entitled to warranty service.

# Table of Contents

| Description   | Page |
|---|------|
| INSTALLATION & OPERATION.....   | 1    |
| Introduction.....   | 1    |
| Hardware.....   | 1    |
| General Description .....   | 2    |
| The Electronics Enclosure .....   | 2    |
| Wetted Parts Subassembly.....   | 6    |
| Functional Description.....   | 7    |
| Theory of Operation.....  | 9    |
| Logic Board .....   | 9    |
| Power Board.....  | 10   |
| Installation .....  | 12   |
| Refrigerator .....  | 12   |
| Sample Container and Bottle Full Sensor.....                                | 12   |
| Connecting Power.....   | 12   |
| Connecting an External Device to the Sampler<br>(Flow-Based Sampling) ..... | 12   |
| Sample Intake Line .....  | 13   |
| Alarm Option .....  | 13   |
| Flow-Through Cell Option .....  | 13   |
| Intake Hose Placement.....  | 14   |
| Running a Test (Manual) Cycle.....  | 15   |
| Setting the Sample Size .....   | 15   |
| Sample Recovery .....   | 16   |
| Sampler Modes .....   | 16   |
| Time Mode.....  | 16   |
| Flow Mode.....  | 16   |
| MAINTENANCE & TROUBLESHOOTING .....   | 17   |
| Maintenance.....  | 17   |
| Cleaning the Wetted Parts.....  | 17   |
| Environmental Protection .....  | 18   |
| Troubleshooting.....  | 21   |
| Checking the Differential Pressure Switch.....                              | 23   |
| Checking the Pinch Solenoid.....  | 23   |
| How to Return Equipment .....   | 24   |
| OPTIONS, ACCESSORIES & SPARE PARTS .....                                    | 25   |
| Optional Wall Mounting.....   | 25   |
| Optional Leg Mount.....   | 26   |
| Heater Option.....  | 27   |
| Alarm Board Option .....  | 28   |
| Totalizer Option.....   | 31   |
| Flow-Through Cell Option .....  | 35   |
| Spare Parts & Accessories .....   | 39   |

## List of Figures

| Figure | Description   | Page |
|--------|---|------|
| 1-1.   | Manning S-5000 Stationary Composite Sampler .....   | 3    |
| 1-2.   | S-5000 Stationary Composite Sampler, Electronics Enclosure<br>Mounted on Refrigerator ..... | 4    |
| 1-3.   | Model S-5000 Operation Controls .....   | 5    |
| 1-4.   | Measuring Chamber .....   | 6    |
| 1-5.   | S-5000 Functional Block Diagram .....   | 9    |
| 1-6.   | S-5000 Sampler Controller Block Diagram .....   | 11   |
| 1-7.   | S-5000 Electrical Connections .....   | 13   |
| 1-8.   | Intake Hose Placement .....   | 14   |
| 1-9.   | Setting the Sample Size .....   | 15   |
| 1-10.  | Model S-5000 Sampler Installation With Refrigerator .....                                   | 20   |
| A-1    | Wall Mount Option .....   | 25   |
| A-2.   | Leg Mount Option .....  | 26   |
| A-3.   | Heater Option .....   | 27   |
| A-4.   | Alarm Board Revision "H" .....  | 30   |
| A-5.   | Alarm Board Revision "I" .....  | 30   |
| A-6.   | Typical Alarm Board Wiring .....  | 31   |
| A-7.   | Totalizer Controls .....  | 32   |
| A-8.   | S-5000 Analog Input Wiring .....  | 33   |
| A-9.   | Flow-Through Cell (Old Version) .....   | 35   |
| A-10.  | Flow-Through Cell (Current Version) .....   | 35   |
| A-11.  | Flow-Through Cell Operation .....   | 36   |
| A-12.  | Flow-Through Cell with Electrically Actuated Ball Valve .....                               | 37   |
| A-13.  | Flow-Through Cell Installation (old version) .....  | 38   |
| A-14.  | S-5000 Wiring Diagram .....   | 42   |
| A-15.  | S-5000 Wiring Diagram with Totalizer .....  | 43   |
| A-16.  | S-5000 Air System Diagram .....   | 44   |

# Installation & Operation

## INTRODUCTION

Congratulations on your purchase of a Manning Environmental, Inc. Model S-5000 Stationary Composite Vacuum Sampler. Your new S-5000 was designed to provide you with the easiest and most cost efficient way to take composite samples. Your S-5000 is backed by the Manning legacy of reliability and will provide you with years of dependable service.

Even if you do not intend to use the sampler immediately upon receipt, please unpack and examine it. Make sure you have received all of the parts you ordered and that no damage has occurred in shipment. This will also familiarize you with the equipment.

We recommend that you follow these steps before attempting to use your sampler:

1. Review this manual
2. Follow the instructions beginning on page 1-12 to assemble your S-5000.
3. Activate a test cycle.

## HARDWARE

### Functional Specifications

|                           |   |
|---------------------------|---|
| Temperature Limits:       | 0°C to 50°C (32°F to 122°F) without optional heater   |
| Maximum Lift:             | 22 ft (6.7 m)   |
| Transport Velocity:       | Minimum of 5 ft/s at 3 ft of lift (1.52 m/s at 1 m) and 2.5 ft/s at 20 ft of lift (0.76 m/s at 6.1 m) |
| Measuring Chamber Volume: | 50 ml to 1 liter within 0.5% of preset volume   |
| Size and Weight:          | Height: 56.6 in. (145 cm)   |
|                           | Width: 24 in. (61 cm)   |
|                           | Depth: 24 in. (61 cm)   |
|                           | Dry Weight: 160 lb (72 kg) with refrigerator  |
| Power:                    | 110-120 VAC, 60 Hz Standard, 220 volt AC, 50 Hz Optional  |

### About this Manual

Every effort has been made to insure that this manual is complete and accurate. Your comments and suggestions for improvement are welcome. Please contact Manning Environmental, Inc. to let us know what we can do better.

## GENERAL DESCRIPTION

The Manning S-5000 Composite Sampler is a stationary unit designed for permanent facility applications where long life and automatic, unattended operation together with field proven high reliability are required. It provides operators with the easiest and most cost efficient way to take composite samples. The simple dial based controller used in the S-5000 allows easy operation of the sampler without sacrificing the ability to run a variety of sampling routines.

The S-5000 is designed so that metal parts, except the bottle full sensor probes never contact the liquid source or the samples, thus avoiding the possibility of metallic contamination of the samples.

The S-5000 is divided into three major sub-assemblies; the electronics enclosure, the refrigerator, and the wetted parts subassembly. As a unit, these sub-assemblies form an environmentally resistant enclosure that conforms to NEMA 4X. See Figures 1-1 and 1-2.

### The Electronics Enclosure

The electronics enclosure is gray polyurethane enamel coated heavy gauge metal assembly that is mounted on top of the refrigerator. A hinged door with a key lock provides protection against tampering or unauthorized changing or setting of controls. A lamp located on the outside lower right-hand corner of the door gives the operator a visual indication that power is applied to the sampler. A removable back panel allows access to internal components. It the electronics enclosure contains all of the following:

#### Controller Electronics and Electrical Components.

The controller electronics and sampler electrical components are located on the back of the front panel, behind the operating controls. The controller electronics consist of a logic board (which has the two dial controls mounted on it), and a power board. The electrical components consists of a power transformer, power line filter, a terminal barrier strip with a power cord attached, and a 10 Amp circuit breaker that also serves as the sampler power switch. Also mounted to the back of the control panel is an air compressor and a 4-way electrically operated air valve.

If the sampler is equipped with either the Alarm Option or the Totalizer Option, then these components are also installed in the electronics enclosure. Alarm Option's circuit board is installed on the back of the control panel. The Totalizer Option's circuitry is installed in a housing mounted to the inside of the enclosure door. If your sampler is equipped with these options, refer to the Options, Accessories, & Spare Parts Section this manual.

#### Operating Controls

Figure 1-3 shows a picture of the operating controls of the 5000. There are several parts that make up the operating controls.

- 1) Power ON/OFF Switch/Circuit Breaker: This two-position rocker switch turns the power to the system on and off. It also provides overload protection to the sampler (10 Amp circuit breaker).
- 2) Function Switch: This four-position switch that can be set to any of the following settings:

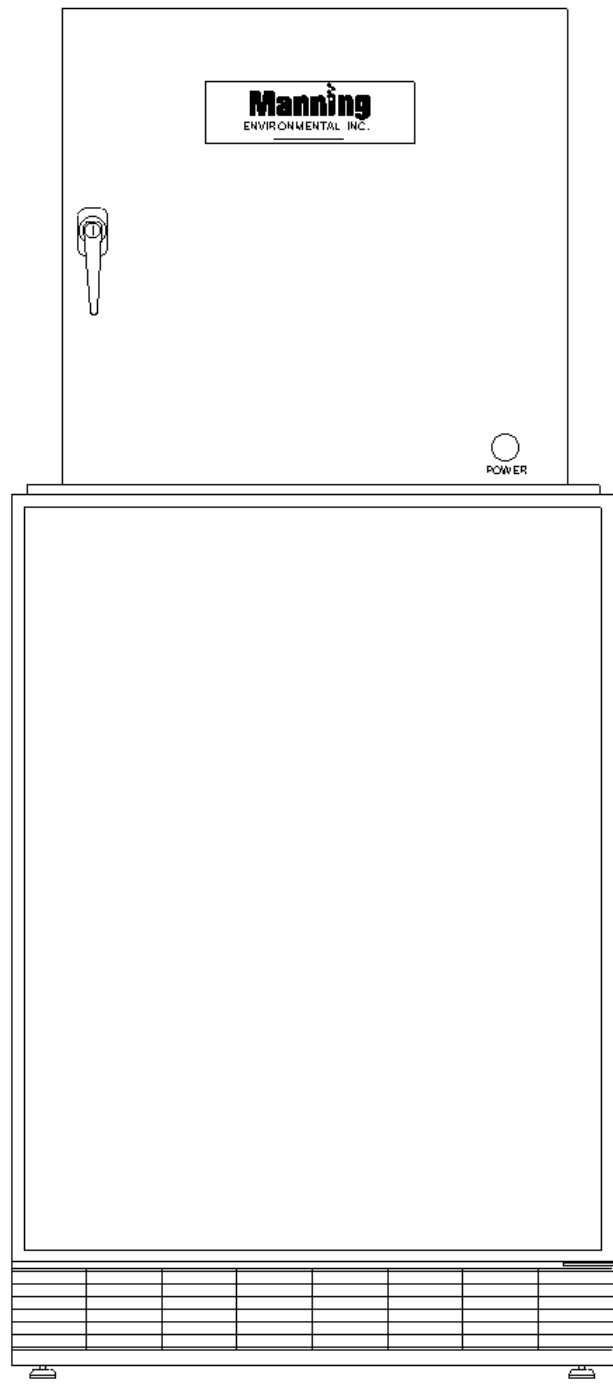

Figure 1-1. Manning S-5000 Stationary Composite Sampler



Figure 1-2. S-5000 Stationary Composite Sampler, Electronics Enclosure Mounted on Refrigerator

- a) MANUAL-CYCLE: Causes one manual sample to be taken.
- b) OFF: Stops all sampler operation but does not disconnect the external (110 VAC) power.
- c) TIME: Allows samples to be taken based on a single time interval set by the timer switch.
- d) FLOW: Allows samples to be taken each time a momentary contact closure is detected from an external device such as a flow meter. If the sampler is equipped with the Optional Totalizer, the Totalizer provides the momentary contact closure to the sampler controller based on a 4-20 mA signal supplied from an external device.

*NOTE:* If the contact closure remains closed while in the FLOW mode, the sampler will take additional samples based on the time interval set on the timer switch.

- 3) Timer Switch: The timer dial allows you to set the time interval between samples when the function switch is turned to TIME. Can be adjusted to ten time intervals ranging from a 3.7-minute interval to a 24-hour interval between samples.

*NOTE:* If an external device such as a flow meter is connected to the sampler with the function switch set to TIME, the sampler will still take samples based on momentary contact closures from the external device.

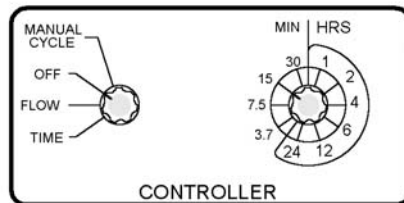

Figure 1-3. Model S-5000 Operation Controls

### Wetted Parts Subassembly

Wetted Parts are any components that come into contact with the sample. The wetted parts are all made of PVC, surgical grade silicone rubber, ABS plastic or stainless steel.

### Measuring Subassembly

The measuring subassembly includes a transparent measuring chamber scaled in milliliters that is located between a chamber top and chamber base assembly. Silicone pinch tubing is attached to the bottom of the chamber base to provide a sample discharge path into the sample collection container. A pinch solenoid assembly is used to seal the chamber base by pinching the silicone tubing during portions of the sample cycle. These assemblies are located on a bracket mounted to the front center of the control panel. The chamber top is connected to the intake line by a short hose that exits the right side of the enclosure. Air lines from the compressor through the 4-way valve supplies air pressure for purging and vacuum for drawing. A differential pressure switch assembly is also located on the chamber top and is used to signal the controller electronics when the chamber is full of fluid during a sample cycle.

Sample volume is adjusted by rotating the spiral tube extending from the bottom center of the chamber top. The sample volume is adjustable from approximately 50 to 1000 milliliters. The measuring chamber is shown in figure 1-4.

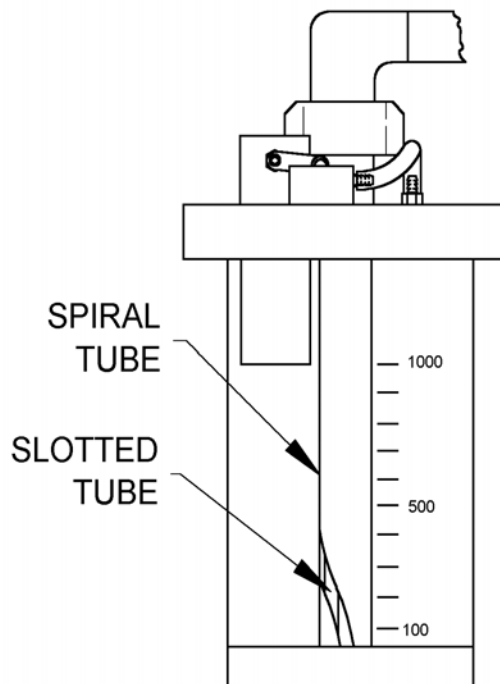

Figure 1-4. Measuring Chamber

**Intake Line**

The intake line is constructed of 5/8" inside diameter tubing with a weighted strainer at the end. The strainer prevents the suction of large particles into the intake line, which could plug the hose or part of the sampler. The weight of the strainer also keeps the hose at the desired level in the liquid to be sampled. The intake line is connected to the short hose's fitting on the outside of the electronics enclosure. The short hose, in turn, is connected to the chamber top.

**Refrigerator Subassembly**

In most sampling applications, it is necessary to maintain the collected samples at a constant temperature. In these instances, the sample containers are stored in a specially treated industrial grade refrigerator, with the sampler electronics enclosure mounted on top. This refrigerator is designed to maintain samples at a constant EPA recommended 4°C. The refrigerator is either painted with a corrosion resistant enamel (white), or is Stainless Steel. An optional factory-installed heater assembly is available for the refrigerator to prevent freezing of the sampled fluid in areas where the temperature will drop below freezing and the sampler is not in a climate-controlled location.

**FUNCTIONAL DESCRIPTION**

The sampling cycle consists of purge, draw, measure, and deposit. See Figure 1-5 for a functional block diagram.

At the beginning of each sampling cycle, the pinch solenoid is energized, which seals off the chamber base. The compressor is started, which causes air to flow through the 4-way valve and into the measuring chamber. With the chamber base closed off, the pressurized air is forced out through the intake hose to purge the line of possible obstructions. Then, the 4-way valve is energized, which changes the air flow through the chamber from pressure to vacuum. Air is now being pumped out of the chamber through the 4-way valve by the compressor (an air line mounted to the top rear of the left side of the completes the air path). Fluid is now drawn up the intake line and into the chamber.

A differential pressure switch, mounted on the top of the chamber, signals the controller when the chamber is full of fluid. The high port of the pressure switch is connected to the chamber top's sensor tube that protrudes down into the chamber. The low port of the pressure switch is connected to the chamber top. When fluid fills the chamber to the point where the bottom of the sensor tube is covered, there is a difference in pressure between the high and low ports of the pressure switch. The pressure switch's internal electrical contacts close, which tells the controller that the chamber is full.

With the measuring chamber full, the controller turns the 4-way valve off. This again reverses the air flow to the chamber from vacuum (draw) back to pressure. The air forces the excess fluid out of the chamber through the intake line to the sample volume set by the position of the spiral tube on the chamber top. The controller then turns the pinch solenoid off, which opens the chamber base, allowing pressure to discharge the sample out the chamber into the sample bottle. The compressor is then turned off, ending the sample cycle.

A bottle full sensor is positioned on the pinch tube to prevent overfilling of the sample container. When its two Stainless Steel probes make contact with the fluid in the container, the controller will not allow any

more samples to be taken until the bottle is emptied.

The sample cycle purge, draw, measure and deposit times are set by circuitry on the controller’s logic board. Two versions of the logic board, one with a 30-second draw and one with a 90-second draw are available to meet various sampling needs. If the controller does not receive a “chamber full” signal at the end of the draw time, it will purge and then draw a second time. If after the second draw attempt the chamber has not been filled with fluid, the sampler purges the intake line, and then turns the pinch solenoid and air compressor off, completing the sample cycle. The following are the sample cycle times:

| Sample Cycle | 30-second draw logic board | 90-second draw logic board |
|--------------|----------------------------|----------------------------|
| Purge        | 12 sec                     | 37 sec                     |
| Draw         | 30 sec                     | 90 sec                     |
| Measure      | 13 sec                     | 45 sec                     |
| Deposit      | 17 sec                     | 25 sec                     |

Note: Draw times refer to the maximum time the sampler will attempt to draw the sample. The actual draw time depends upon how long it takes to fill the chamber. Due to tolerances in the electronic components on the logic board, the sample cycle times may vary slightly.

**Flow**

With the function knob in the FLOW position, the S-5000 Sampler can be driven by an external device providing a momentary (approximately ¼ second) contact closure to provide flow-proportional sampling. If the contact closure remains closed, the sampler will take samples based on the time interval selected on the time control knob. The contact closure must be 1K Ohms or less.

**Time**

An internal crystal quartz clock on the controller’s logic board, along with the time interval select switch on the control panel controls the frequency of sampling cycles. Ten sampling intervals, from 3.5 minutes to 24 hours, can be selected. With the function switch set to TIME, placing the POWER switch to ON will immediately start the sampling cycle and automatically initiate a new sampling cycle at the end of each time frame. If an initial (immediate) sample is not desirable, turn the POWER switch ON, then place the function switch to the TIME position. This sequence delays the sample command for the time period set on the Time switch. Thereafter, at each elapsed interval, the sampler will automatically initiate a new sample cycle.

NOTE: A momentary contact closure will activate a sample cycle when the unit is in TIME mode.

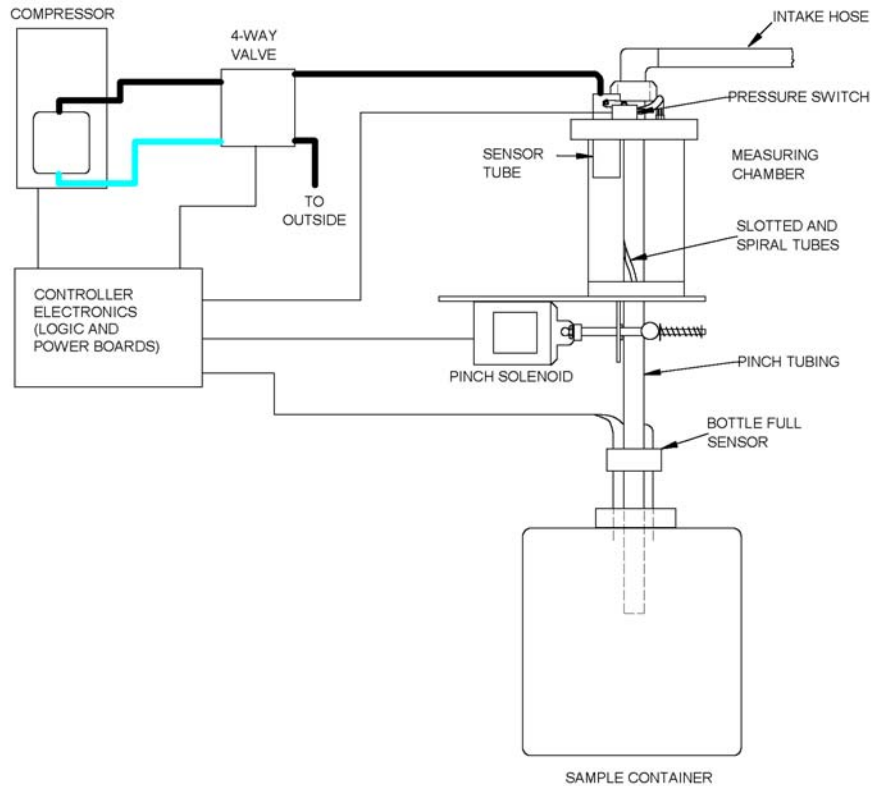

Figure 1-5. S-5000 Functional Block Diagram.

## THEORY OF OPERATION

Two printed circuit boards make up the sampler’s electronic controller. The logic board is mounted to the back of the control panel by its two rotary switches (Function and Time). The power board is mounted behind the logic board, where it plugs into a 36-pin card edge connector. See figure 1-6.

### Logic Board

The logic board contains a clock circuit, sample initiation circuit, power up latch, and sequential logic circuit. It is connected to the Power Board by a 14-pin Dual Inline Pin (DIP) connector and 10-wire ribbon cable.

The clock circuit contains an oscillator and associated counter and divider circuitry to produce the ten different sample time intervals that are selected by the Time rotary switch. The output of this circuit is input to the sample initiation circuit.

The sample initiation circuit contains the logic components that select the method (time, flow, or Manual Cycle via the Function Switch) that trigger a sample cycle. The output of this circuit is input to the power up latch. The bottle full signal is input to this circuit to inhibit sample initiation when a bottle full condition is present.

Due to the way that the Time and Flow inputs are coupled, the sampler can still be triggered by a flow input when in the TIME mode,

The power up latch supplies power to the sequential logic circuit during the actual sampling cycle and allows for instant manual “shut off”, even in the middle of a sequence. Its output also provides a signal to turn the compressor on. An “end of sequence” output from the sequential logic circuit is fed into the power up latch to turn it off at the end of a sample cycle.

The sequential logic circuit provides the actual timing and control for the sample cycle. When a sample cycle is initiated, the circuit is turned on and the signal to turn on the pinch solenoid is made active (the compressor is turned on by the power up latch). After the purge time is completed, the draw signal is made active, which is used to turn the 4-way valve on. When the pressure switch detects that the measuring chamber is full of fluid, the chamber full signal deactivates the draw signal (4-way valve turns off) and the measure time is started. At the completion of the measure time, the pinch signal is deactivated, starting the deposit portion of the sample cycle. At the end of the deposit time, the circuit sends the “end of sequence” signal to the power up latch, which turns off the compressor and power to the sequential logic circuit.

If a chamber full signal is not received by the sequential logic circuit before the end of the draw time, the circuit goes back to purge and then initiates a second draw time. If by the end of the second draw time, no chamber full signal is received, the circuit completes the sample cycle (measure and deposit) and signals the power up latch as described above.

### **Power Board**

The power board contains a +12 VDC supply; power control circuits for the compressor, 4-way valve, and pinch solenoid; and paths to the logic board for bottle full, chamber full, Flow and Time signals.

Low voltage AC from the transformer secondary is rectified and regulated to produce the +12 VDC power. This supply is used to power the logic board.

The power control circuits control AC voltage to the compressor, 4-way valve and pinch solenoid. They receive AC line voltage from the power line filter and low voltage AC from the transformer secondary. The logic board provides the input controls signals for these three circuits.

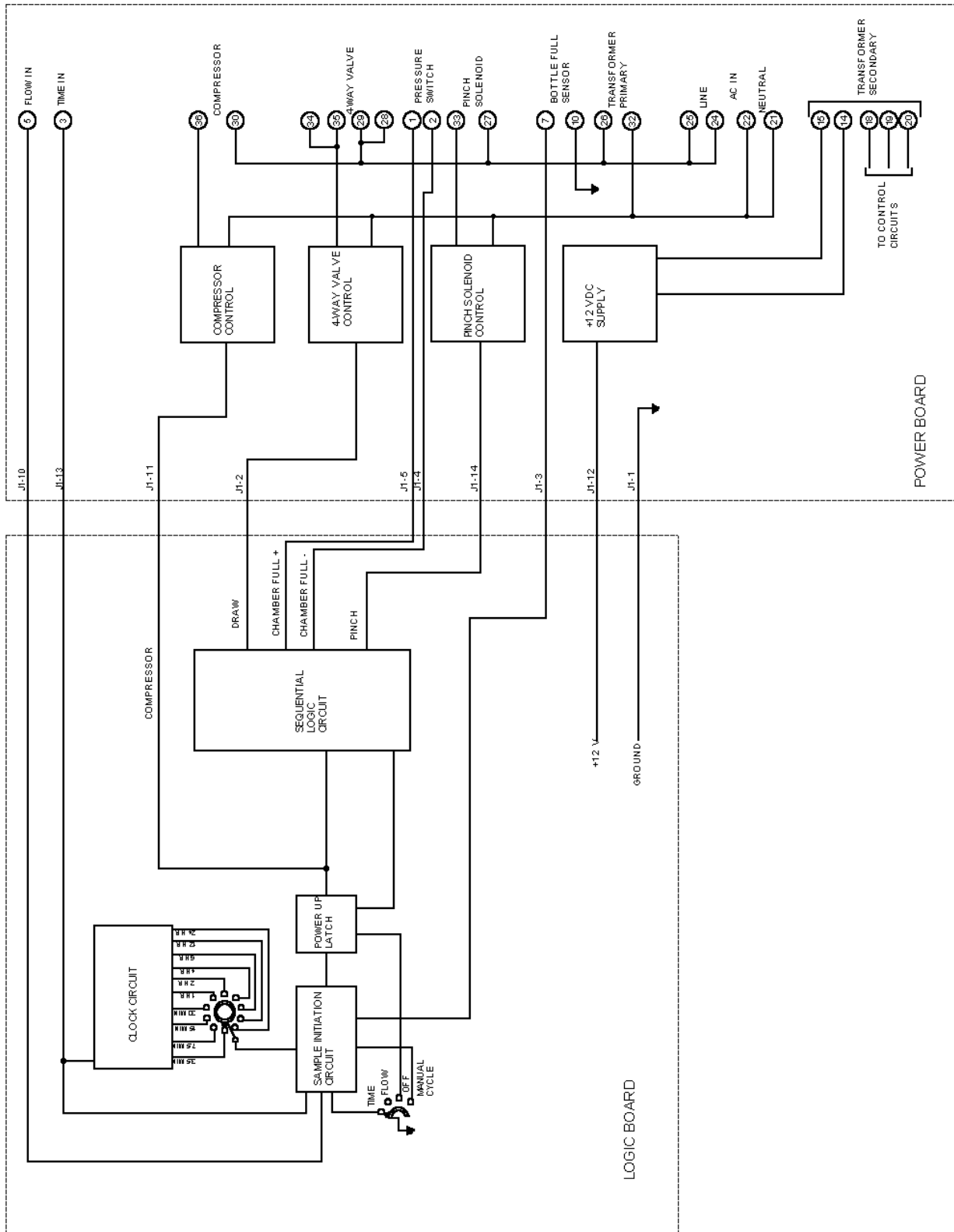

Figure 1-6. S-5000 Sampler Controller Block Diagram

## INSTALLATION

Install the sampler on a firm, level surface adjacent to the sampling point. The sample must be located at a point higher than the maximum anticipated fluid level (head height). The sampler must also be installed in a location with sufficient drainage so that water will not pool around the base of the sampler/refrigerator. In most cases the S-5000 comes fully assembled to make installation quick and easy. If the sampler is installed outdoors, you should enclose it in a shelter. This is especially important in areas where temperatures drop below freezing or other adverse weather conditions are expected. Manning offers an optional full-sized NEMA 3R fiberglass enclosure designed to protect the sampler. The NEMA 3R enclosure can be ordered with an optional heater, light, and/or fan.

If the sampler was ordered with an NEMA 3R enclosure, the enclosure should be positioned first and electrical power should be connected to it. Then, place the sampler into the enclosure. In most cases, the samplers with refrigerators come assembled (electronics enclosure mounted on top of refrigerator). If mounting of the electronics enclosure is required, refer to the Maintenance Section of this manual for instructions. For samplers with the wall mount or floor mount options, refer to the Options, Accessories, & Spare Parts Section of this manual.

### Refrigerator

Refer to the instruction manual accompanying the refrigerator for detailed instruction on its operation. Install the four adjustable feet on the refrigerator by screwing them into the threaded holes in the four corners on the bottom of the refrigerator. Adjust the feet to level the refrigerator. After power has been connected to the refrigerator (see Connecting Power below), adjust the refrigerator's thermostat for the proper temperature. Allow the refrigerator to run for 24 hours to stabilize its temperature.

### Sample Container and Bottle Full Sensor

Position the sample container so that the pinch (discharge) tube is inside of its opening (this will be inside of the refrigerator except for floor and wall mounted units). The bottle full sensor is designed to friction-fit against the outer wall of the pinch tube. Insert the pinch tube through the center of the bottle full sensor ring and position the bottle full sensor so that its probes are below the top of the sample container by at least the volume of one sample. (Note: Once a sample has been drawn into the chamber, it cannot be completely purged out. Therefore, allowing extra space in the sample container helps to prevent over filling.) Attach the two wires from the bottle full sensor cable to the short ends of the sensor probes by firmly pushing the female crimp terminals onto the probes.

### Connecting Power

AC power cords (one for the sampler electronics enclosure and one for the refrigerator) are provided with the sampler. The sampler can also be hardwired, although an electrician should always do hard wiring. Connect the sampler to 120VAC, 60HZ power, with ground. Failure to provide proper grounding for the sampler or connecting the sampler to an improperly wired power outlet (line and neutral reversed) will cause the sampler to operate erratically and possibly damage it.

### Connecting an External Device to the Sampler (Flow-Based Sampling)

For flow-proportional sampling, the external device that will trigger the sampler (contact closure) is connected to the sampler's TB-1 Terminal Board. See figure 1-7. A factory-installed pigtail is provided to allow easy connection to the external device. The pigtail is located above the power cord on the right side-

of the electronics enclosure. For installations where direct wiring is required, remove the pigtail and watertight bulkhead connector and connect wires directly to TB-1. Note: for samplers equipped with the Totalizer Option, refer to the Options, Accessories, & Spare Parts Section in this manual for connection instructions.

**Immediate Sampling**

Connect wires to the FLOW and COMMON terminals on TB-1 (this is the normal factory setup). A sample will be taken immediately on contact closure.

**Time Delay Sample**

Connect the wires to the COMMON and TIME terminals on TB-1. Sample initiation will be delayed by the time setting on the control panel Time knob.

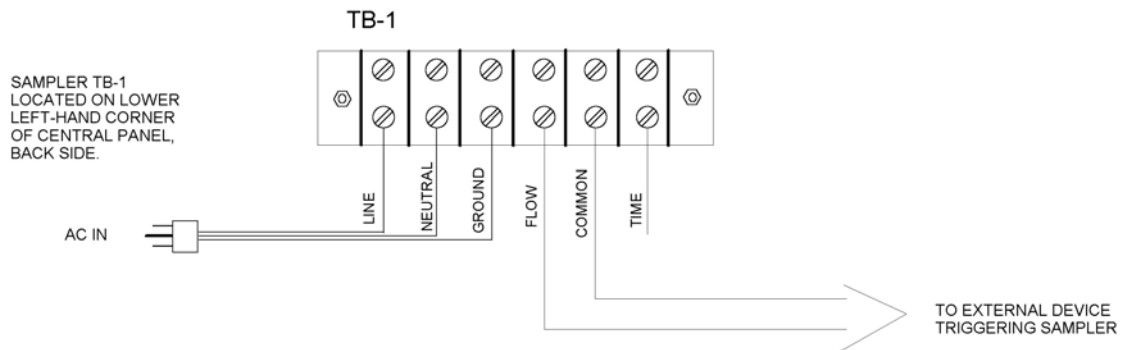

Figure 1-7. S-5000 Electrical Connections

**Sample Intake Line**

Attach the intake hose to the short hose that is affixed to the side of the sampler. If the sampler is installed in a NEMA 3R enclosure, route the other end of the hose through the hole in the side of the enclosure. In areas where the temperature may drop below freezing for extended periods of time, insulating the intake hose will aid in preventing icing. Shading the intake hose from sunlight will help prevent algae from growing inside of the hose in applications where that is a concern.

**Alarm Option**

If your sampler is equipped with the Alarm Option, refer to the Options, Accessories, & Spare Parts Section of this manual for information on Alarm operation and connections

**Flow-Through Cell Option**

The flow through allows the sampler to be used with pressurized sources. If your sampler was ordered with the Flow-Through Cell Option, refer to Options, Accessories, & Spare Parts Section for detailed information.

**Intake Hose Placement**

Place the intake hose strainer directly in the channel flow, not in an eddy or at the edge of the flow. In channels with debris, provide deflection to prevent clogging of strainer holes. The weight supplied with the intake hose is usually sufficient to prevent the intake from being pulled to the surface of a fast channel.

The correct vertical position of the strainer depends on the type of sample being taken. Placing the strainer at the bottom of the flow results in a heavier concentration of solids in the sample, while placing the strainer at or near the top of the flow results in heavier concentration of oils, fats, and other floating or suspended contaminants.

The intake hose should be positioned so the hose can drain between sample cycles and no low spots exist which would trap water. It may be necessary to cut the hose to length for proper placement. Figure 1-8 shows correct and incorrect hose placement.

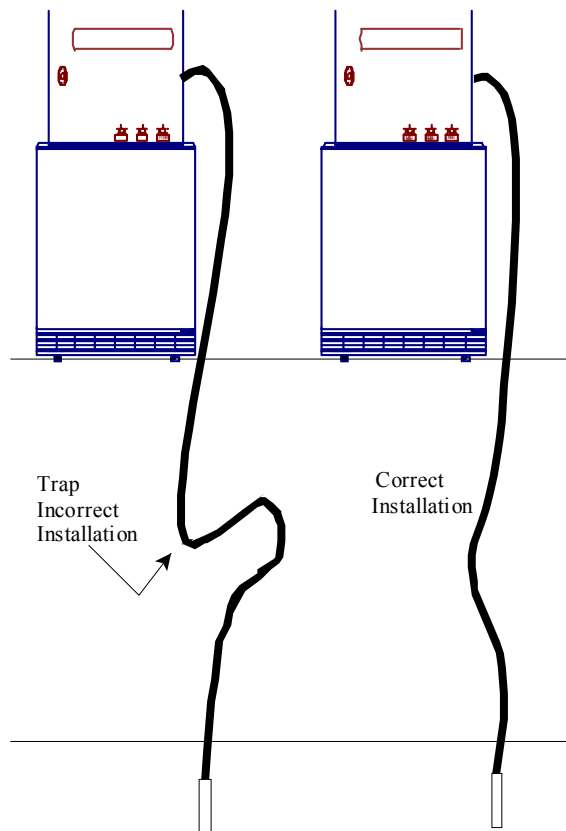

Figure 1-8. Intake Hose Placement

### RUNNING A TEST (MANUAL) CYCLE

The Manual Cycle position on the Controller Function switch allows the operator to initiate one sample cycle to test the sampler operation or collect a manual (“grab”) sample. While it is not mandatory that you run a test cycle, it is recommended to assure proper operation and to familiarize you with the sampler operation.

1. Turn the Function Switch on the Controller to OFF. Then turn the main power switch on the central panel to the “ON” position.
2. Submerge the strainer of the intake hose in a container of clean water. The amount of water should be enough to keep the strainer covered completely for several test cycles.
3. Turn the Function Switch on Controller to MANUAL-CYCLE.
4. After the sample cycle has been completed, turn the Function Switch to OFF.

### SETTING THE SAMPLE SIZE

1. Remove the two wing nuts securing the chamber top, and lift the chamber top slightly.
2. Twist the spiral tube so that its opening aligns with the inner slotted tube at the level corresponding to desired sample volume. See Figure 1-9. Make sure the spiral tube stays seated up against the bottom of the chamber top.
3. Replace the chamber top and verify the alignment with the graduations on the chamber.
4. Replace the wing nuts and tighten finger-tight, making sure all o-rings are evenly compressed and will seal.
5. Activate a manual cycle.
6. Measure the sample deposited.
7. Repeat steps 1 - 6 as needed to fine-tune sample volume.

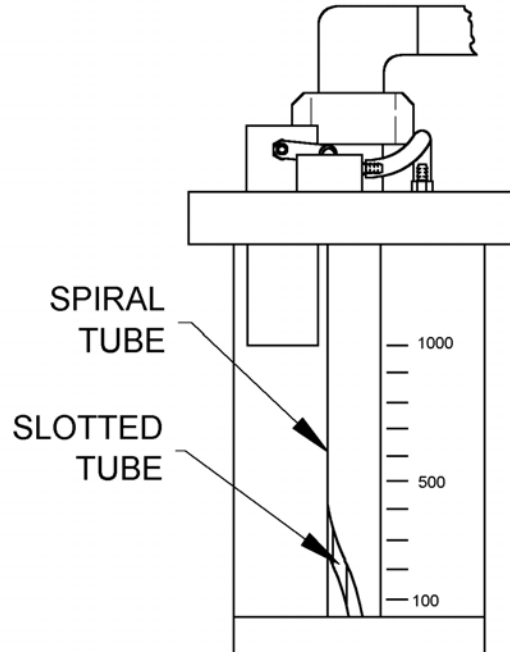

Figure 1-9. Setting the Sample Size.

**SAMPLE RECOVERY**

Immediate sample recovery is not required since the sampler will automatically shut down when the sample container is full. However, sample analysis may require quick recovery to maintain sample freshness or to add chemicals.

**SAMPLER MODES**

Once the sampler is installed, the operator then sets up the controls for the type of sampling operation desired. Sampling is based on time, flow or a combination of both. Refer to the Function Description and Electrical Connections sections for more information.

**Time Mode**

This mode allows you to take a sample after time period you set has elapsed. Once a sample is taken, the timer resets and begins to count down the time period until the next sample event. Turning the Function Switch to TIME and then setting a sample time interval on the Timer Switch puts the sampler in Time Mode. The Timer Switch can be set to take a sample every 3.7, 7.5, 15, or 30 minutes, and 1, 2, 4, 6, 12, or 24 hours. If a sample is desired immediately after the Sampler is set, set the Function and Timer Switches while the Power Switch is in the OFF position. When the sampler is turned ON, a sample will immediately be taken and then additional samples will be taken after each time interval elapses. If a sample is not desired until after the first timer interval has elapsed, set the Function and Timer Switches while the Power Switch is set to ON. The sampler will then take the first sample after the time period set on the Timer Switch has elapsed.

**Flow Mode**

When the Function Switch is set to the FLOW mode, the S-5000 will take a sample for each momentary dry circuit contact closure it receives from an external device (connected to the FLOW and COMMON terminals of TB-1). The contact closure must be 1 k ohms or less. If the contact closure remains closed, the sampler will revert to time mode and will take one sample for each time interval set on the Timer Switch. If the external device is connected between the COMMON and TIME terminals on TB-1, then the sample initiation is delayed by the time setting on the Timer Switch.

# Maintenance & Troubleshooting

## MAINTENANCE

Your sampler requires only minimal maintenance to ensure proper and reliable operation.

### Cleaning the Wetted Parts

1. Standard PVC wetted parts are not autoclavable.
2. The wetted parts should be cleaned when they are coated.
3. Placing the intake hose in a container of clean water and running several test cycles can accomplish a quick cleaning of the wetted parts.
4. The use of some solvents to clean the wetted parts may leave a residue that could contaminate your sample. Additionally, some solvents will break down Polyethylene and/or PVC.
5. Keep the bottle full sensor dry and free from build up.
6. Leaks should be repaired immediately.
7. Clean up any spilled fluid inside the electronics enclosure and refrigerator.
8. The refrigerator has an auto-defrost feature. If ice builds up in the refrigerator, it should be removed.
9. Observe the operation of the sampler during normal operation or by running a Manual Cycle to insure that it is operating correctly.

*Note:* Solvents and solvent contaminated fluids must be disposed of according to approved procedures.

### Intake Hose

1. Remove the intake hose. Remove the strainer if necessary.
2. Wash the intake hose and strainer using a cleaning solution appropriate for your installation. The use of methylene chloride or other solvents may leave a residue that could contaminate your sample. Use a test tube brush to scrub the internal surfaces of the strainer, pull the brush through the hose with a wire to clean the internal surfaces of the hose.
3. Rinse the hose and strainer thoroughly in clean water and reassemble.

### Measuring Chamber

*Caution:* Do not allow water to enter the differential pressure switch. Remove the pressure switch and its tubing before cleaning the chamber top. Unplug the tubing for additional protection. Failure to keep the pressure switch dry will result in switch failure.

1. Remove the short intake hose connection from the chamber top by unscrewing it.
2. Remove the air line from the chamber top by pressing down on the quick-release ring on the fitting while pulling the air line.
3. Remove the two wires from the pressure switch by carefully removing the spade terminals from the pressure switch.
4. Remove the two wing nuts from the top of the measuring chamber and lift the chamber top and chamber top support ring off the chamber.
5. Remove the measuring chamber by lifting it off of the chamber base and clear of the chamber top.
6. Remove the silicone tubes that connect the pressure switch to the chamber top at the chamber top fittings. The chamber top support ring with the pressure switch can now be separated from the chamber top.
7. Check the two measuring chamber o-rings, one on the chamber top and one on the chamber base, for gouges and imperfections. Replace the o-rings if necessary. Do not lubricate these o-rings.
8. Wash the chamber parts with an appropriate cleaning solution. A test tube brush can be used to scrub the

- internal surfaces of the top fittings, slit tube and sleeve. Clean the chamber base and pinch tube.
9. Rinse all parts thoroughly in clean water. Blow water out of all tubing.
  10. Inspect the o-ring on the chamber top slotted tube (remove the spiral tube if necessary) for gouges and imperfections. Replace if necessary. Lubricate this o-ring with an appropriate silicone o-ring lubricant.
  11. Reassemble all parts.

### Pinch Tubing

1. Inspect the pinch tubing for cracks and stiffness. Replace if necessary.
2. The pinch tubing is attached to the chamber base by a spring clip. Use a pair of pliers to loosen and slide the clip off of the chamber base. Then, remove the pinch tubing.

### Environmental Protection

Once a year (or as necessary) replace the two Zerust® Vapor Capsules located in the back of the electronics enclosure. If the sampler is in an area of high humidity, you may use additional desiccant at your discretion.

### Other Maintenance Actions

The following instructions are provided to assist in maintaining the S-5000 Sampler.

#### Accessing Electronics Enclosure Internal Components

To access the internal components (such as TB1) inside the electronics enclosure it is necessary to remove the back panel. ***Do not attempt to remove the control panel from the front of the electronics enclosure.***

1. While supporting the back panel, remove the 16 sheet metal screws and flat washers that secure it to the enclosure.
2. Remove the back panel.
3. Installation is the reverse of removal. When reinstalling the back panel, do not over tighten the screws as this will over compress the gasket.

#### Removing the Electronics Enclosure from the Refrigerator

(See Figure 1-10)

1. Turn the sampler off and disconnect it from power.
2. Disconnect the intake hose from the sampler.
3. Disconnect any other wiring (flow input, alarms, etc.) from the sampler.
4. Open the refrigerator door and remove the sample container.
5. Remove the bottle full sensor from the pinch tubing. Disconnect the two wires from the bottle full sensor's probes by grasping the female crimp connectors on the wires and pulling them off the probes.
6. Open the door on the electronics enclosure and pull the pinch tubing and bottle full sensor cable up through the rubber step grommet on the bottom of the enclosure and remove the grommet.
7. The electronics enclosure has two mounting bars attached to its bottom that secure it to the top of the refrigerator. Remove the four screw, lock washers and washers from the refrigerator.
8. Carefully lift the electronics enclosure off of the refrigerator. Be careful not to damage the gasket on the top of the refrigerator mounted around the hole that the pinch tube is routed through.
9. Put the four screws, lock washers and washers back into the holes in the refrigerator top. Cover the hole in the refrigerator top to prevent dirt or moisture from collecting inside.

**Installing the Electronics Enclosure on the Refrigerator**

(See Figure 1-10)

1. Remove the four screws, lock washers and washers from the holes in the top of the refrigerator.
2. Note the location of the gasket that surrounds the hole in the top of the refrigerator. Carefully position the electronics enclosure on top of the refrigerator, lining up the holes in the mounting bars with the holes in the refrigerator top. Be careful not to damage the gasket.
3. Install the four screws, lock washers and washers through the mounting bars and into the holes in the top of the refrigerator.
4. Open the door to the electronics enclosure. Insert the pinch tubing and bottle full sensor cable through the stepped grommet. Route the pinch tubing and bottle full sensor cable through the holes in the bottom of the enclosure and top of the refrigerator. Install the stepped grommet into the hole in the bottom of the electronics enclosure with the small hole that the bottle full cable goes through is oriented towards the back.
5. Open the refrigerator door. Make sure that the pinch tubing is not kinked. Connect the bottle full sensor to the cable by pushing the female crimp connectors firmly onto the short ends of the sensor's probes.
6. Run the pinch tubing through the center hole in the bottle full sensor.
7. Position the sample collection container underneath the pinch tubing, and adjust the height of the bottle full sensor on the pinch tubing by grasping the tubing and then sliding the sensor up or down as required.
8. Connect the sampler intake hose, any other external wiring (flow, alarms, etc.) and power to the sampler.

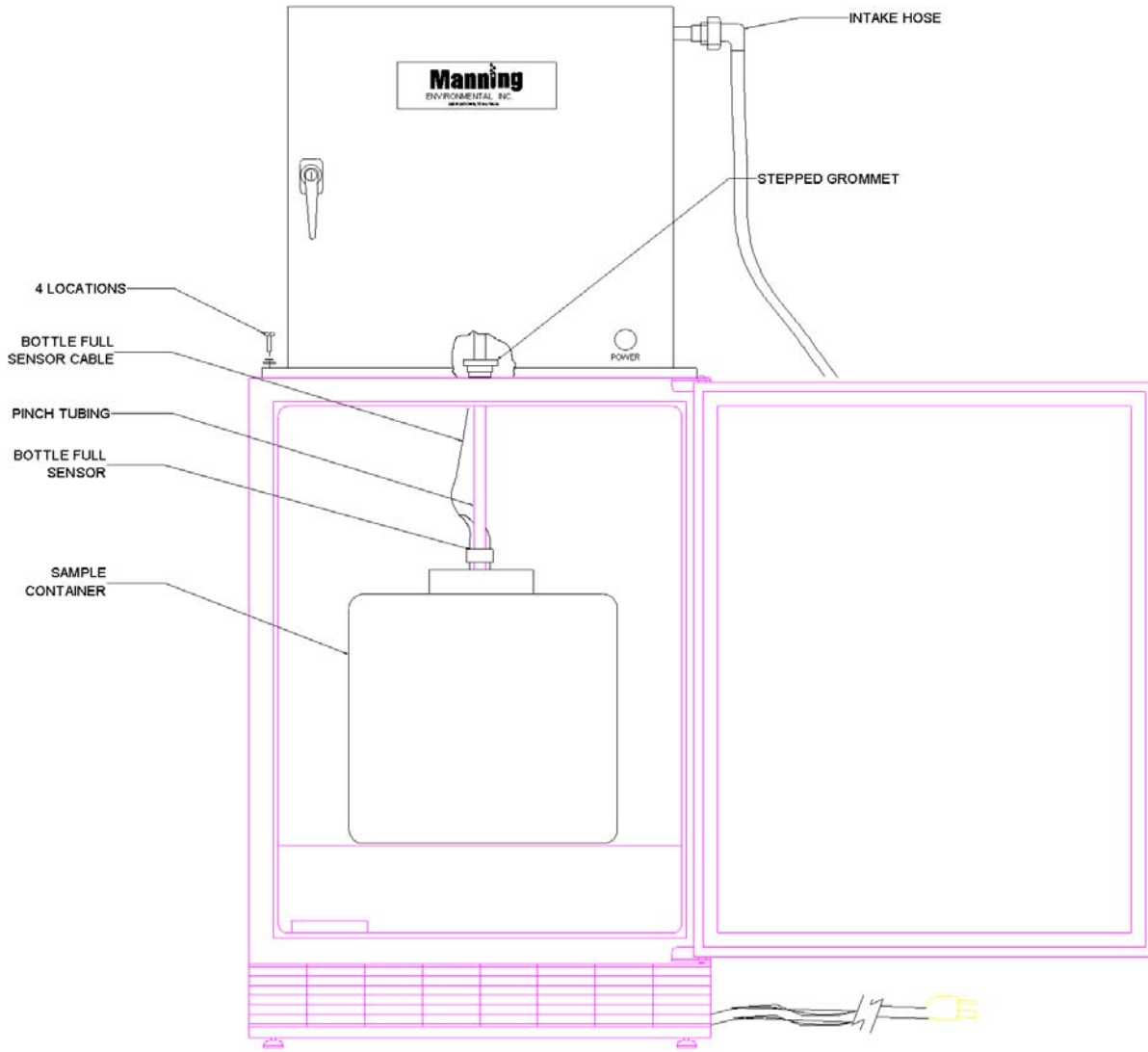

Figure 1-10. Model S-5000 Sampler Installation With Refrigerator

## TROUBLESHOOTING

Troubleshooting instructions are based on a logical sequence of events leading to a malfunction. If problems occur, look for the simplest solution first. Is power connected? Are any connections loose or wires broken? Review the problem, review normal operating procedures, and then check one possibility at a time starting with the easiest to verify. If you continue to have a malfunction, call the Manning Environmental, Inc. Service Department at 1-800-863-9337. We can often assist you over the phone. We can also advise you on whether certain repairs are best done in the field or at our facilities.

### Wiring Diagram

A Wiring Diagram for the S-5000 sampler is located at the back of this manual to assist in troubleshooting.

| Trouble  | Probable Cause  | Remedy  |
|--|---|---|
| Nothing Works  | 1) Loose Connections<br>2) Circuit Breaker Tripped<br>3) Controller Problem | 1) Tighten connections<br>2) Reset Breaker, check for shorts<br>3) Repair/Replace Controller  |
| Weak Draw  | 1) Air Leak<br><br>2) Pinched intake hose<br><br>3) Clogging                | 1) Be sure that the wing nuts on the top of the chamber top are tight. Check the tubing and fittings for leaks. Check the seals in the measuring chamber. Replace defective parts.<br>2) Unpinch the hose. Replace the tube if it was damaged.<br>3) Clean hose and lines |
| Short samples<br>a) Sample spurts into intermittently, triggering fill sensor with approximately 1/4 sample.<br>b) See Weak Draw | Intake hose drawing air. (Intake not completely submerged)                  | Position the strainer to avoid taking air into the line   |

|  |  |  |
|--|--|--|
| <p>Sample drains slowly or not at all from the chamber to the bottles.</p> | <p>1) Inoperative pinch solenoid.<br/><br/>2) Controller Failure.</p>  | <p>1) Check pinch solenoid for clogging and proper operation during a manual test cycle.<br/>2) Replace controller</p>   |
| <p>Chamber overfilling, cycling double at fill.</p>                        | <p>Bottle Full Sensor Inoperative.</p>   | <p>Replace Bottle Full Sensor.</p>   |
| <p>Compressor just hums.</p>   | <p>Compressor Failure.</p>   | <p>Replace Compressor.</p>   |
| <p>Compressor runs but there is no purge or sample taken.</p>              | <p>1) Clogged Hose<br/>2) Pinch valve not closing.<br/><br/>3) Controller not giving signal.<br/><br/>4) Leaks</p> | <p>1) Clean Hose.<br/>2) Check the voltage at the solenoid, if 110 volt AC; then the pinch valve needs to be replaced. If not, then the controller needs to be repaired or replaced.<br/>3) With an AC voltmeter, check for 110 volts at the solenoid valve. If no voltage, replace the controller.<br/>4) With the chamber top off, check to see if compressed air is coming through the holes at the top of the post. If not, the compressor is the problem. If air is getting to the chamber top, then the pinch valve is not closing. Repair or replace the pinch valve.</p> |
| <p>Sampler will not start cycle.</p>                                       | <p>Pressure Switch Stop Activated.</p>   | <p>Set dial to OFF then back to TIME, FLOW, or MANUAL CYCLE.</p>   |

|                                       |   |  |
|---------------------------------------|---|--|
| Runs and appears to constantly purge. | Pressure Switch failed.                   | Check the pressure switch by following the directions on page 23. If the pressure switch has failed, replace it. |
| Solenoid Valve Chatters.              | Solenoid valve in first stage of failure. | Replace solenoid valve, DO NOT WAIT FOR COMPLETE FAILURE!  |
| Sampler works part of the time only.  | Compressor Component failure.             | Replace controller or both PC boards.  |

**Checking the Differential Pressure Switch**

Pressure switch failure can have serious consequences so it is important to replace the switch as soon as possible when it begins to fail.

The pressure switch will fail in one of two ways. It can short, in which case the sampler will switch from purge to draw to measure very quickly (the controller gets a chamber full signal from the shorted pressure switch as soon as it goes into the draw portion of the sample cycle), and no sample will be taken. It can also remain open, in which case the chamber fills completely to the top, and the sampler controller never receives a chamber full signal. The sampler will draw for the entire draw time (either 30 or 90 seconds), and then re-try to take the sample, just as if no fluid was drawn. A float ball located on the chamber top below the air line is designed to prevent fluid from being sucked into the air lines if the chamber overfills in most cases.

*Caution:* If your pressure switch fails completely, water can flow into the chamber and into the compressor, resulting in expensive repairs.

To check the pressure switch follow these instructions.

1. Disconnect the wires leading to the pressure switch.
2. Set the Function Switch to MANUAL-CYCLE. During the draw cycle, touch the wires together before the chamber fills completely. **Do not let the chamber fill completely.** If the draw stops and the measure (purge) begins, replace the pressure switch. If the draw does not stop, immediately turn the Function Switch to Off. Check wiring to pressure switch and controller circuit boards.
3. Call the Manning Service Department (800-863-9337) if you need assistance.

**Checking the Pinch Solenoid**

The pinch solenoid assembly, located underneath the measuring chamber and mounted to the bracket, seals off the chamber base during the purge, draw, and measure portions of the sample cycle. If it becomes noisy during operation, this could be a sign of impending failure. To check the pinch solenoid, follow these instructions.

1. Check to see if the pinch tubing is centered in the pinch assembly. If the tubing is cocked to one side, this will cause the solenoid to hum.
2. Verify that the solenoid is securely mounted to the bracket.
3. Inspect the springs and other pinch assembly components for wear.
4. Disconnect the two wires from the back of the pinch solenoid. Using an Ohmmeter, test the resistance of the solenoid coil. A good solenoid will measure approximately 6.5 Ohms. If the resistance is much less than this, the coil is drawing excessive current and should be replaced. If the current draw of the pinch solenoid is allowed to increase too much, damage to the power board will result.

## HOW TO RETURN EQUIPMENT

Call or write the Manning Environmental Service Department before returning any equipment for repair. Many problems can be diagnosed and resolved over the telephone. Manning will issue a Return Material Authorization (RMA) number if it is deemed necessary that the equipment be returned for repair.

If you do need to return equipment, follow these guidelines:

- ◆ Pack equipment carefully, preferably in the original carton.
- ◆ Enclose specific information about the problem.
- ◆ Enclose a contact name and phone number in case our Factory Service Department needs additional information.
- ◆ Enclose a purchase order authorizing repairs.
- ◆ Ship the equipment to the address below. Our Receiving Department will not accept collect shipments.

*Note: Equipment being returned for repairs should be reasonably clean. Due to the health risks posed by exposure to some fluids that may be sampled, Manning reserves the right to charge additional labor fees if cleaning of the sampler equipment is necessary to safely repair it.*

The Service Department phone number is (800) 863-9337. The Service Department will notify you of the type of repair needed and an estimate of the cost of the repairs. Manning will ask for authorization before proceeding.

Address For Repairs:

Service Department  
Manning Environmental, Inc.  
1904 South Austin Avenue Suite 102  
Georgetown, Texas 78626

# Options, Accessories, & Spare Parts

## Optional Wall Mounting

*NOTE: The Wall Mount Option is no longer available. This information is provided for owners of older S-5000 Samplers*

This option allows the sampler enclosure to pivot out from the wall so that you can access the electronics without removing the sampler from the mountings.

If you ordered the wall mount option with your sampler, you will receive hardware and more detailed drawings with the wall mount. Figure A-1 shows the wall mount option.



20-1/4

FRONT VIEW

SIDE VIEW

Figure A-1-Wall Mount Option

**Optional Leg Mount**

*Note: The Leg Mount Option is no longer available. This information is provided for owners of older S-5000 Samplers.*

Figure A-2 shows the leg mounts available for the Model S-5000. If you ordered this option, you will receive hardware and more detailed drawings with your order.

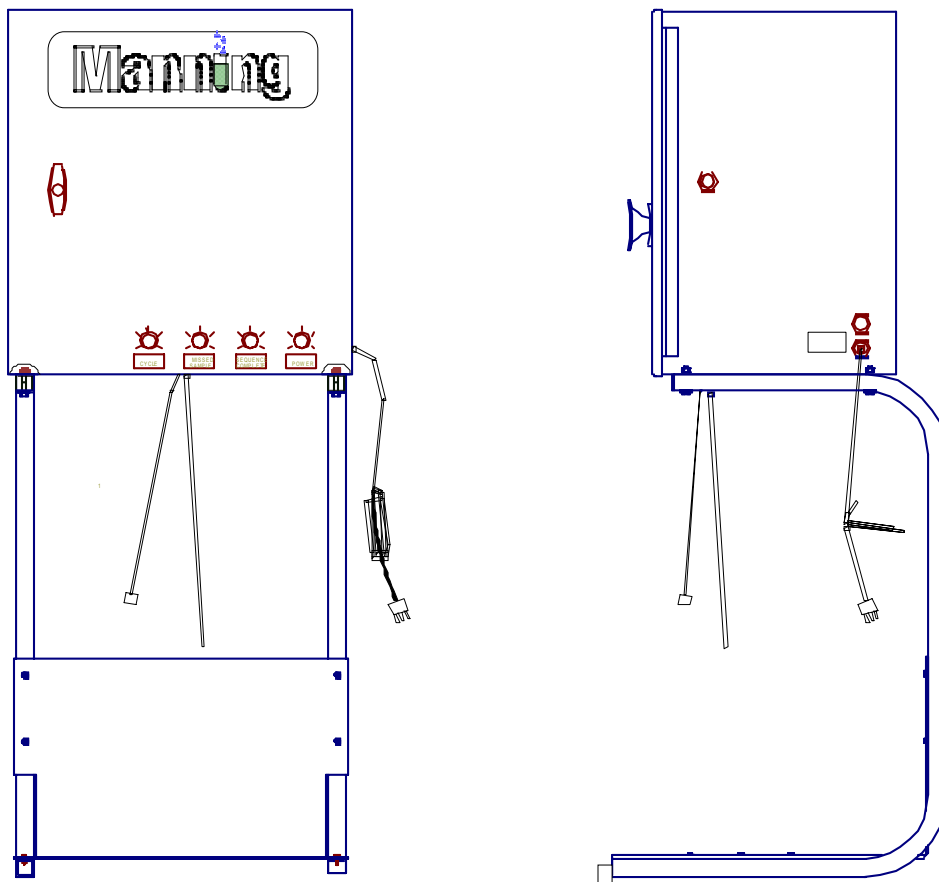

Figure A-2 Leg Mount Option

### Heater Option

For sampling in temperatures below 32°F Manning recommends an optional heater. Figure A-3 shows the heater as it appears when installed in the sampler. The heater is a factory-installed option.

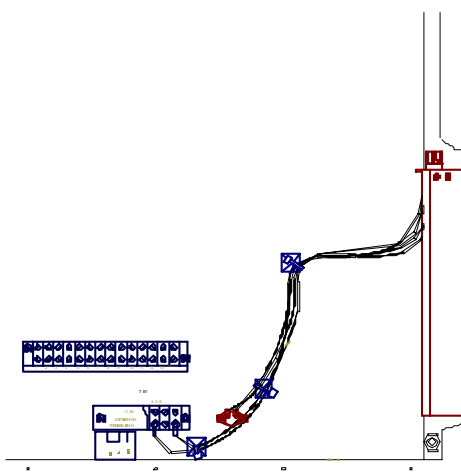

Figure A-3 Heater Option

## Alarm Board Option

The Alarm Board Option gives the sampler the ability to provide 5A-rated relay contacts (up to 32VDC, 120/240VAC) that are closed when certain events (alarms) occur. The three alarms possible are Missed Sample (Line Plugged), Bottle Full and Sample Cycle. The board is mounted in front of the Power Board on the inside of the sampler enclosure using standoffs, and is connected to the Logic and Power Boards with a ribbon cable.

The relay contacts can be used to illuminate a lamp on the front door of the sampler enclosure, activate an audio alarm located in the sampler housing, or trigger an external device supplied by the operator. Depending upon the configuration ordered, the board may provide relay contacts for one or more of the events listed above.

## Differences between Alarm Board Revisions

For samplers manufactured after August 1999, a newer Revision "I" Alarm Board is being used. The Revision "H" Alarm Board is no longer available. The differences are as follows:

Revision "H": This board carries the old Manning Part Number of 04971-XX. They have single-pole relays that provide one set of normally open contacts for each alarm. They contain a fourth location for a custom relay configuration. The board has an 8-position terminal board for making connections to the lamps or other external devices. The Alarm Board interconnects with the Logic and Power Boards using a special ribbon cable (Part Number 810001, with 2 male and one female DIP header), and has one 14-pin DIP socket (J1) on it. See Figure A-4.

Revision "I": This board carries the current Manning Part Number of 889021. It uses double-pole, single throw relays that provide two sets of normally open contacts for each event. It contains relay locations for only the three alarms listed above. The board has a 12-position terminal board for making connections to the lamps or other external devices. It also has two 14-pin DIP sockets (J1 and J2) connected in parallel. These two sockets allow the board to interconnect with the Logic and Power boards using a much simpler 14-pin ribbon cable assembly, Part Number 810035. See Figure A-5.

Except for instances where a custom relay configuration was used, the boards are interchangeable. Ribbon cable P/N 810001 used with the Revision "H" Alarm Board can also be used with the Revision "I" board.

## Alarm Functions

### MISSED SAMPLE (LINE PLUGGED):

The missed sample (line plugged) alarm circuit provides a relay contact closure when the sampler fails to draw a full sample after the normal sample cycle and retry cycle (the pressure switch is not actuated). The relay will remain closed until reset by a subsequent successful sample cycle.

When power is first applied to the sampler, the Missed Sample relay may be energized. Taking a sample clears this condition.

### BOTTLE FULL:

The Bottle Full alarm circuit is activated when the sample bottle is filled (fluid is making contact with both probes of the Bottle Full Sensor), or when the sampler is placed in the MANUAL SAMPLE mode.

**SAMPLE CYCLE:**

The Sample Cycle alarm circuit is activated when the sampler is taking a sample (the compressor is on).

By wiring in parallel the second set of relay contacts (Revision "I" board only) for the Bottle Full and Missed Sample alarms, a single "Sampler Trouble" output is created which can be used to alert operators to check the sampler. If additional relay contacts are required, the alarm board relays can be used to actuate customer-provided relays. See Figure A-6 for typical alarm wiring.

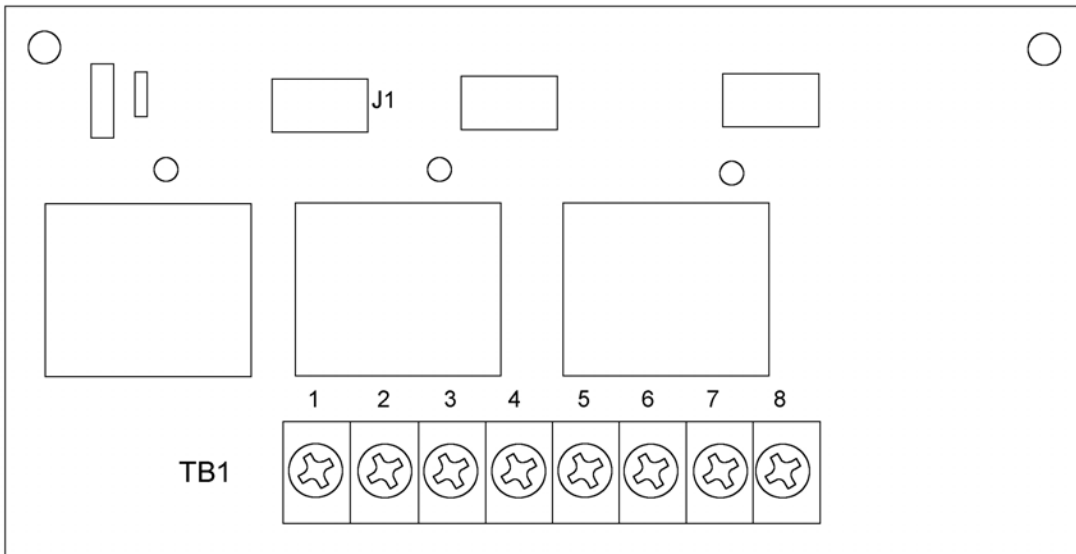

Output connections: Bottle Full- TB1-1 & TB1-2; Sample Cycle- TB1-3 & TB1-4; Missed Sample- TB1-5 & TB1-6

**Figure A-4. Alarm Board Revision “H”(Old)**

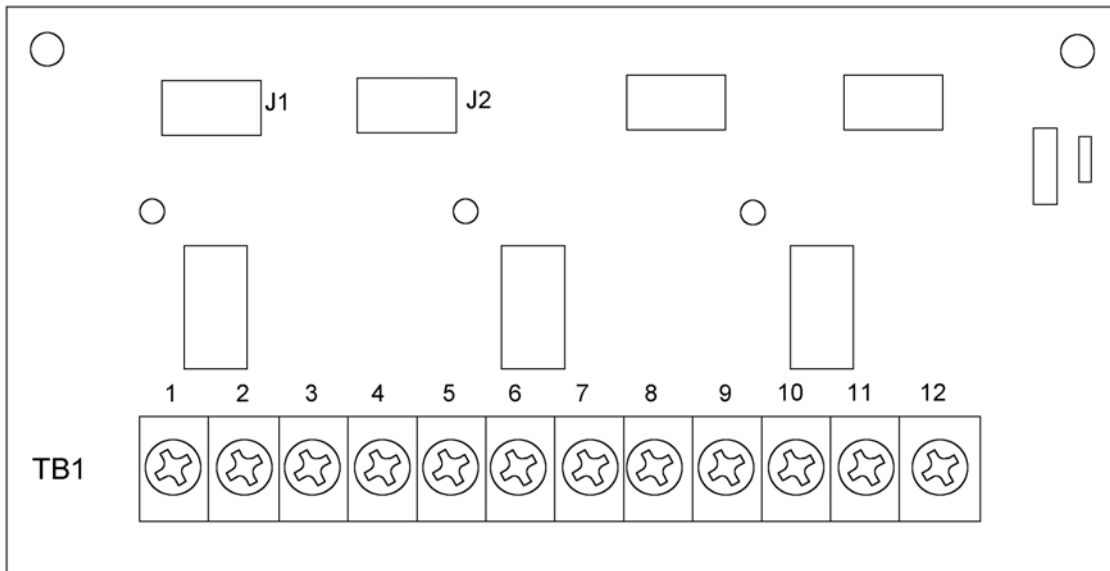

Output connections: Bottle Full- TB1-1 & TB1-2 and TB1-3 & TB1-4; Sample Cycle- TB1-5 & TB1-6 and TB1-7 & TB1-8; Missed Sample- TB1-9 & TB1-10 and TB1-11 & TB1-12

**Figure A-5. Alarm Board Revision “I” (Current)**

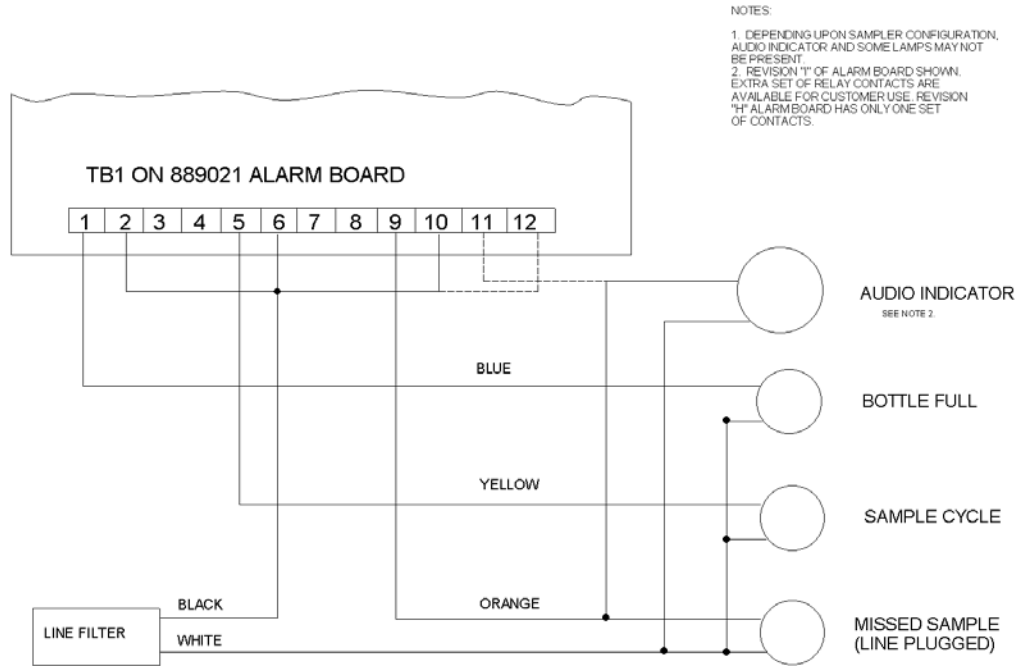

Figure A-6 Typical Alarm Board Wiring

**Totalizer Option**

The totalizer accepts a 4-20 mA analog signal input that is representative of flow and provides a momentary contact closure output to the sampler controller that will cause a sample to be taken when the sampler is in the FLOW mode. The totalizer assembly is mounted to the inside of the electronics enclosure door. It receives +12 VDC power from the sampler controller.

A 3-digit Maximum Flow Input switch is provided to standardize the input signal to a maximum flow value (gallons per minute, liters per minute, etc.). A single-digit Sample Rate switch and a 3-position multiplier (X10, X100, X1000) are provided to select the quantity of flow between samples. See Figure A-7.

Two Input Adjust potentiometers are provided to adjust the minimum (ZERO) and maximum (MAX) analog signal levels to the totalizer for calibration purposes. A Light Emitting Diode (LED) located to the right of the Input Adjust potentiometers lights whenever the analog signal is above the maximum level or below the minimum level.

A relay in the totalizer assembly provides the momentary contact closure to the sampler controller FLOW input. A ¼ Amp fuse on the totalizer circuit board provides protection to the contact output. An optional 6-digit non-resetable counter allows recording of total flow. The counter will increment one digit for 10 times each accumulated maximum flow level. A second LED, located to the right of the counter window lights every time that the totalizer triggers the sampler

The analog input signal is connected to the FLOW (+) and COMMON (-) terminals on TB1 located on the back of sampler control panel. See Figure A-8. A pigtail is provided that exits the right side of the electronics enclosure through a watertight fitting above the power cord. The pigtail and fitting may be removed if direct wiring is desired. In areas where electrical interference is possible, (i.e. lightning), surge protection installed at both the sampler and the analog signal transmitter is recommended to help prevent damage to the equipment.

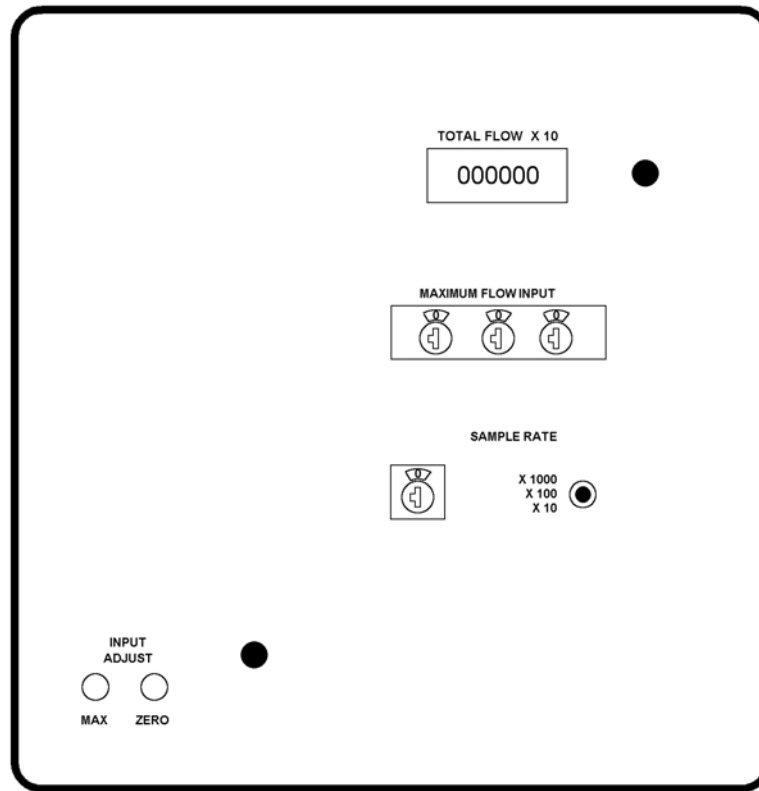

Figure A-7. Totalizer Controls

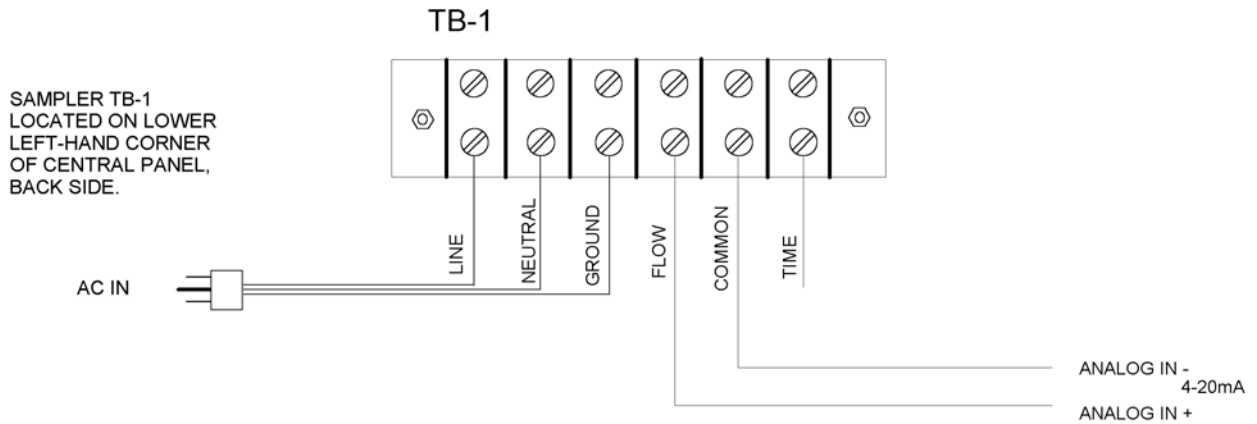

Figure A- 8. S-5000 Analog Input Wiring

**Input Calibration**

1. Connect a current loop calibrator or other 4-20mA source that can be adjusted to 4.00mA and 20.00mA. The totalizer places a 250-Ohm load on the current loop.
2. Turn the sampler power on.
3. Turn the over-range pot fully CCW, and the under-range pot fully CW.
4. With the input set to 4mA, turn the under-range pot CCW until the LED just goes out.
5. With the input set to 20mA, turn the over-range pot CW until the LED just goes out.
6. With the input set to 4mA, turn the under-range pot CW until the LED just goes on.
7. With the input set to 4mA, turn the over-range pot CCW until the LED just goes on.
8. Repeat steps 4 through 7 until no further adjustment is necessary.

NOTE:           a) This is a precision adjustment, and the pots should be turned slowly or “tweaked” to obtain the point where the LED just comes on or goes off.  
                     b) The calibration will be invalid if the current source is deficient.

**Maximum Flow Rate Input**

Obtain the maximum flow per minute- when the current input to the sampler is 20 mA. Set the three MAX FLOW INPUT switches to read this maximum flow rate. If the maximum rate is more than three digits, use the three most significant digits. This flow rate can be in any units- liters, gallons, etc. Use a small flat-blade screwdriver to set the switches.

**Sample Rate Interval Adjustment**

To select the interval between samples to be taken, adjust the sample rate switch and multiplier to read the required interval in volume units (gallons, liters, etc.) between samples. This should correspond to the same

units as previously set in the MAX FLOW INPUT. Typically, the intervals between samples are from 4 to 10 times the maximum flow rate. The wide range available allows for very frequent or only occasional sampling.

**EXAMPLES:**

| Max Flow Rate (20mA) | Max Flow Input | Sample Rate | X    | Samples Each |
|----------------------|----------------|-------------|------|--------------|
| 200 GPM              | 200 GPM        | 1           | 10   | 10 Gallons   |
| “ “                  | “ “            | 2           | 10   | 20 Gallons   |
| “ “                  | “ “            | 3           | 10   | 30 Gallons   |
| “ “                  | “ “            | 3           | 100  | 300 Gallons  |
| “ “                  | “ “            | 3           | 1000 | 3000 Gallons |
| 500 GPM              | 500 GPM        | 1           | 10   | 10 Gallons   |
| “ “                  | “ “            | 2           | 10   | 20 Gallons   |
| “ “                  | “ “            | 3           | 10   | 30 Gallons   |
| “ “                  | “ “            | 3           | 100  | 300 Gallons  |
| “ “                  | “ “            | 3           | 1000 | 3000 Gallons |

**Flow-Through Cell Option**

The S-5000 Sampler is designed for use with non-pressurized fluid sources. In some instances, it is necessary to sample from a pressurized pipe or other source. The Flow-Through Cell (FTC) allows sampling from pressurized sources by relieving the pressure. The FTC operates by opening the stream to the atmosphere, thereby reducing the effective pressure to zero.

In the fall of 2000, Manning changed the design of the FTC. With the old design, the FTC was mounted on the side of the sampler with a bracket. In the current design, the FTC may be mounted wherever it is practical, normally close to the pressurized source.

Both versions of the FTC operate the same way. See Figures A-9 and A-10.

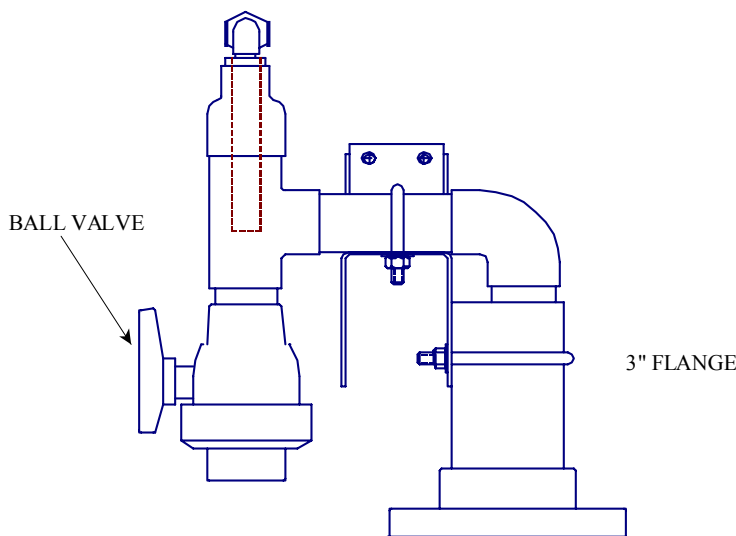

**Figure A-9. Flow-Through Cell (Old Version)**

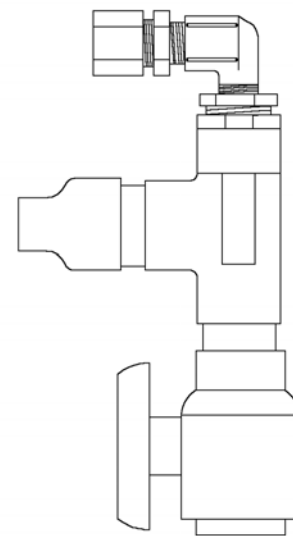

**Figure A-10. Flow-Through Cell (Current Version)**

**Operation**

Refer to Figure A-11. The pressurized source is connected to the ball valve on the inlet of the FTC. The ball valve is used to adjust the flow to not more than 50 GPM at 50-PSI maximum. It also allows fluid to the FTC to be shut off for cleaning and maintenance.

Fluid then enters the clear PVC tee and flows out of the FTC to an open-air drain. The third opening on the clear PVC tee is attached to the sampler intake hose using a bushing and fittings. An intake tube attached to the bushing allows the sampler to draw fluid from and purge fluid back to the FTC. The bushing can be easily removed for cleaning.

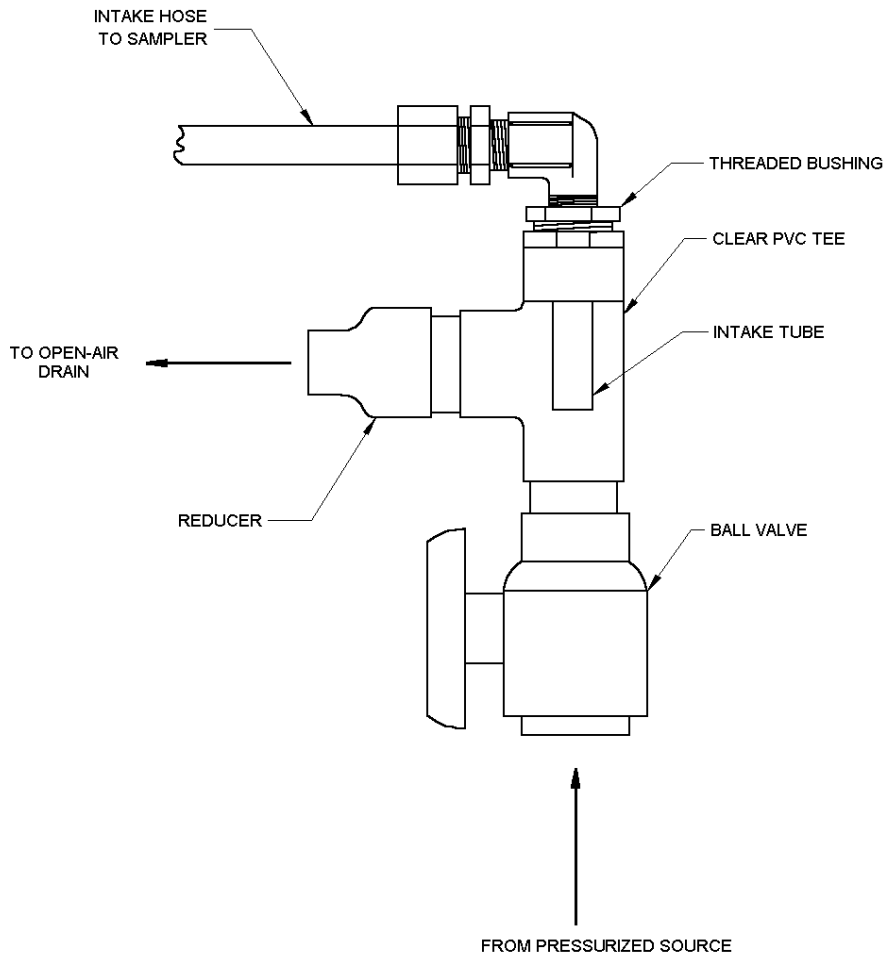

Figure A-11. Flow-Through Cell Operation

**Installation**

**General**

Appropriate piping to the FTC is required so that the pressurized source and open-air drain are available. The sampler must be located higher than the FTC, and the intake line to the sampler must be routed so that it does not have any dips where fluid could collect.

It is important that the pipe from the FTC outlet to the drain does not have any reductions in it. Any reductions or excessive elbows will increase the pressure at the intake point for the sampler.

The FTC is designed to operate with a flow of not more than 50 GPM at 50-PSI. In instances where the flow cannot be reduced sufficiently with the manual ball valve, an addition pressure reduction valve must be installed before the FTC,

Normally, flow though the FTC is continuous. In some applications is desirable to only have flow through the FTC during a sample cycle. To accomplish this an electrically actuated ball valve may be installed close to the pressurized source. The valve is opened only during the sample cycle. See Figure A-12.

Most electrically actuated ball valves require a relay to control them. This relay and the sampler can be controlled by a PLC or other control circuitry. If the Alarm Option is installed on the S-5000 Sampler, the SAMPLE CYCLE relay can be used to control the ball valve relay. See the Alarm Option section for more information on the SAMPLE CYCLE relay.

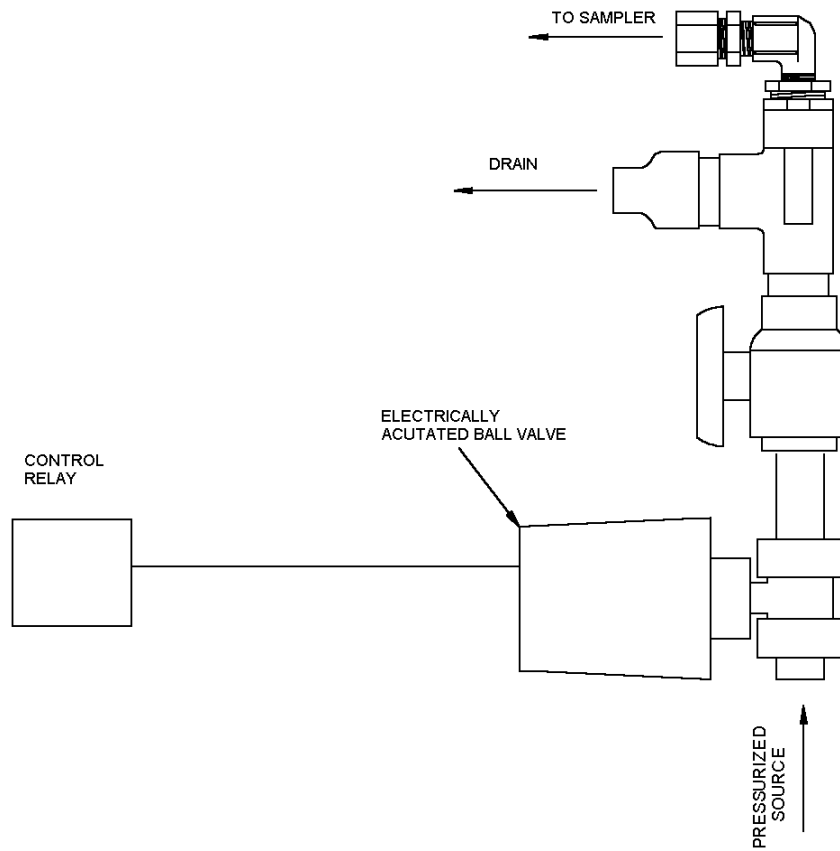
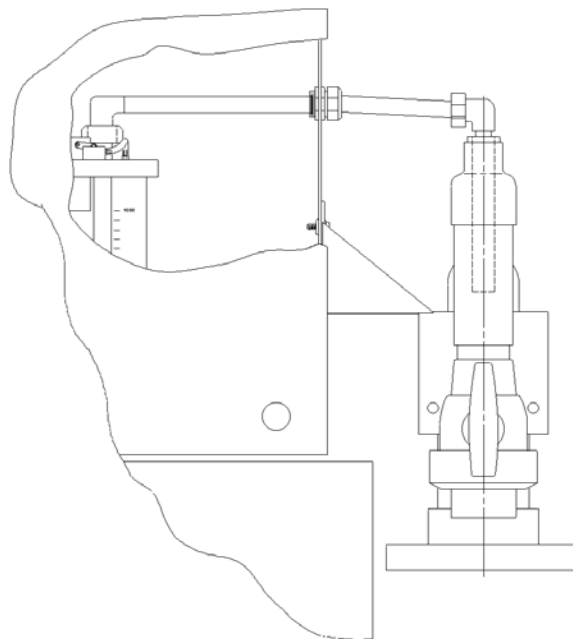

Figure A-12. Flow-Through Cell with Electrically Actuated Ball Valve

**Old Version FTC**

1. Mount the flow-thru cell on the appropriate side of the enclosure using the hardware provided (the flow through cell can be ordered with either a left or right mount). See figure A-13.
2. Loosen the knurled nut on the flow-thru cell elbow. Slip the intake hose through the nut until it seats against the elbow. Tighten the knurled nut. *Do not use pliers or over-tighten*
3. Attach the incoming 1-1/2" pipe to the ball valve.
4. Secure the 3" flange to the drain line.
5. Adjust the ball valve so that flow does not exceed 50 GPM at 50-PSI maximum



**Figure A-13. Flow-Thru Cell Installation (old version)**

**Current Version FTC**

1. The FTC is shipped with the manual ball valve and reducer loose. The 1-1/2" to 3/4" reducer pipe may be discarded if not needed. Attach the manual ball valve to the pressurized line with 3/4" pipe.
2. Attach the other end of the ball valve to the inlet of the clear PVC tee using 1-1/2" pipe. A 4" piece of 1-1/2" pipe is supplied to attach the other end of the manual ball valve to the clear PVC Tee. A longer piece of pipe may be substituted if required.
3. Connect the outlet of the clear PVC Tee (through the reducer, if used) to the open-air drain using appropriate piping.
4. Attach the sampler intake hose to the FTC using the compression fitting.
5. Adjust the ball valve so that flow does not exceed 50 GPM at 50-PSI maximum.
6. The FTC may be left freestanding or may require mounting to a bracket or brace depending upon location.

## SPARE PARTS & ACCESSORIES

The following is a list of spare parts available from the Manning Environmental Parts Depart. Contact the Parts Department at 1-800-863-9337.

### PINCH/CHAMBER SUPPORT BRACKET PARTS

**Note: In May 1985 Manning changed the design of the S-5000 Pinch Assembly. Some S-5000's manufactured before May 1985 are retrofitted with the current Pinch Assembly.**

- P/N 889226 - Pinch Assembly with bracket (May 1985 to present)
- P/N 889423 - Pinch Solenoid, 115VAC (May 1985 to present)
- P/N 675420 - Pinch Solenoid, 115VAC (pre-May 1985)
- P/N 548015 - Pinch Spring (May 1985 to Present, 2 per unit)
- P/N 763012 - Retaining Ring, "E" (May 1985 to present, to hold Pinch Springs in place. 2 per unit)
- P/N 548031 - Pinch Spring (pre-May 1985, 2 per unit)
- P/N 579404 - Pull Bar
- P/N 579403 - Pinch Bar (May 1985 to present)
- P/N 579576 - Pinch Bar (pre-May 1985)
- P/N 911410 - Screw, Drive (to attach pull bar to solenoid, 2 per unit)
- P/N 912137 - Well-nut (to mount solenoid to bracket, 4 per unit)
- P/N 579405 - Pinch Plate (May 1985 to present)
- P/N 531124 - Insert, Sheet Edge (May 1985 to present, to mount Pinch Plate to Bracket, 4 per unit)
- P/N 579401 - Rod, Chamber Hold-down (2 per unit)
- P/N 579553 - Pad, Bounce

### MECHANICAL AND ELECTRICAL PARTS

- P/N 675415 - Compressor, 115VAC
- P/N 565861 - Valve, Air, 4-way, 115VAC
- P/N 640522 - Transformer 115VAC
- P/N 675416 - Power Line Filter
- P/N 638574 - Power Switch/Circuit Breaker, rectangular rocker type
- P/N 675427 - Indicator Light, Amber (Power and Alarms)
- P/N 552097 - Fitting, Air, Quick-Disconnect, Straight (1ea 4-way valve and chamber top)
- P/N 552098 - Fitting, Air, Quick-Disconnect, 90° Elbow (2ea compressor and 3ea 4-way valve)
- P/N 566911 - Air Tubing, Clear
- P/N 566913 - Air Tubing, Blue
- P/N 783027 - Zerust© Vapor Capsule

**MEASURING ASSEMBLY PARTS**

- P/N 579402** - Non-Toxic Measuring Chamber
- P/N 889006** - Chamber Top - Non-Toxic
- P/N 889050** - Chamber Base - Non-Toxic
- P/N 542180** - O-ring, Chamber Top and Chamber Base
- P/N 542186** - O-ring, Chamber Top Slotted Tube
- P/N 542201** - O-Ring, Chamber Top Inlet
- P/N 638522** - Pressure Switch Assembly
- P/N 566900** - Tubing, Pressure Switch (8" per Chamber Top)
- P/N 579411** - Support Ring, Chamber Top
- P/N 566899** - Pinch Tube (18" per unit)
- P/N 579406** - Clamp, Pinch Tube to Chamber Base

**ELECTRONIC/CONTROLLER PARTS**

- P/N 889000** - Logic Board 30 Second Draw
- P/N 889001** - Logic Board 90 Second Draw
- P/N 488004** - Knob, Logic Board switches (2 per unit)
- P/N 886311** - Alarm Board Assembly
- P/N 810035** - Ribbon Cable, 14-wire, Alarm Board to Power Board
- P/N 889621-4** - Power Board
- P/N 889079** - Totalizer Board without Counter
- P/N 889015** - Totalizer Board with Counter

**INTAKE HOSES AND STRAINER**

- P/N 552018** -Strainer, 5/8" Intake, PVC
- P/N 566901** - Bulk Hose 5/8" ID, Nylon-reinforced PVC
- P/N 566918** - Bulk Hose, 5/8" ID, Clear PVC
- P/N 889811** - 10' 5/8" Clear PVC Hose Assembly with strainer
- P/N 889812** - 25' 5/8" Clear PVC Hose Assembly with strainer
- P/N 889038** - 10' 5/8" Nylon-reinforced PVC Hose Assembly without strainer
- P/N 889008** - 25' 5/8" Nylon-reinforced PVC Hose Assembly with strainer
- P/N 889484** - 100' 5/8" Nylon-reinforced PVC Hose Assembly without strainer
- P/N 889529** - Short Hose Assembly (chamber top to outside of sampler housing)
- P/N 889808** - 10' 5/8" Clear PVC Hose Assembly without strainer
- P/N 889054** - 100' 5/8" Nylon-reinforced PVC Hose Assembly with strainer
- P/N 889809** - 25' 5/8" Clear PVC Hose Assembly without strainer
- P/N 889382** - 50' 5/8" Nylon-reinforced PVC Hose Assembly with strainer
- P/N 889053** - 25' 5/8" Nylon-reinforced PVC Hose Assembly without strainer

**BOTTLES AND RELATED SPARE PARTS**

**P/N 889822** - Bottle Full Sensor

**P/N 889804** - 5 Gallon HDPE Pail with Lid

**P/N 889715** - 2.5 Gallon Glass Bottle with Teflon-lined Cap

**P/N 687535** - 5 Gallon Rectangular HDPE Bottle with Cap

**OTHER PARTS**

**P/N 889013** - Refrigerator, 120VAC, White Enamel

**P/N 889049** - Refrigerator, 120VAC, Stainless Steel

**P/N 450076** - Mounting Bar, Sampler to Refrigerator (2 Per Unit)

**P/N 717660** - Manual, S-5000

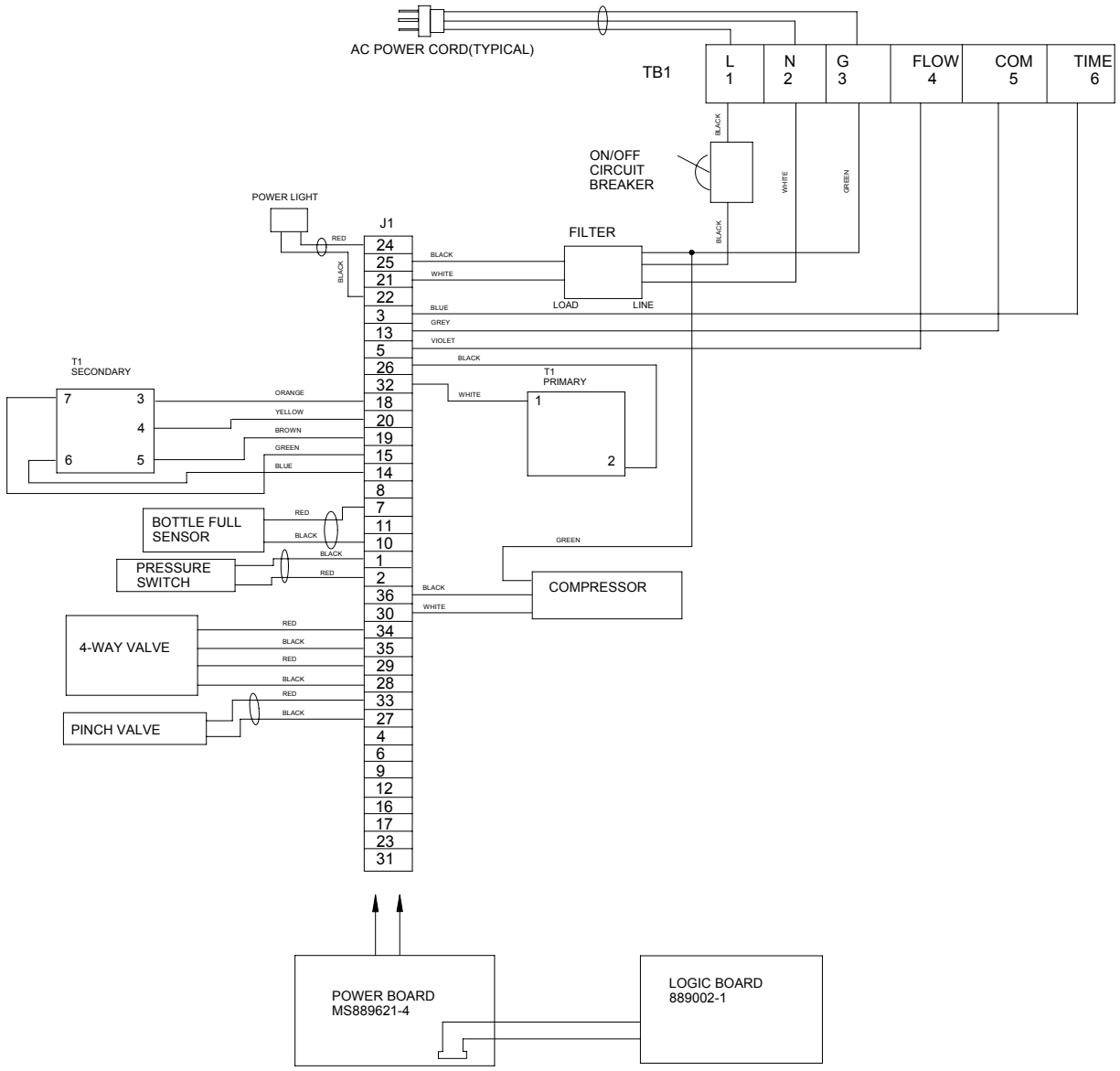

Figure A-14. S-5000 Wiring Diagram

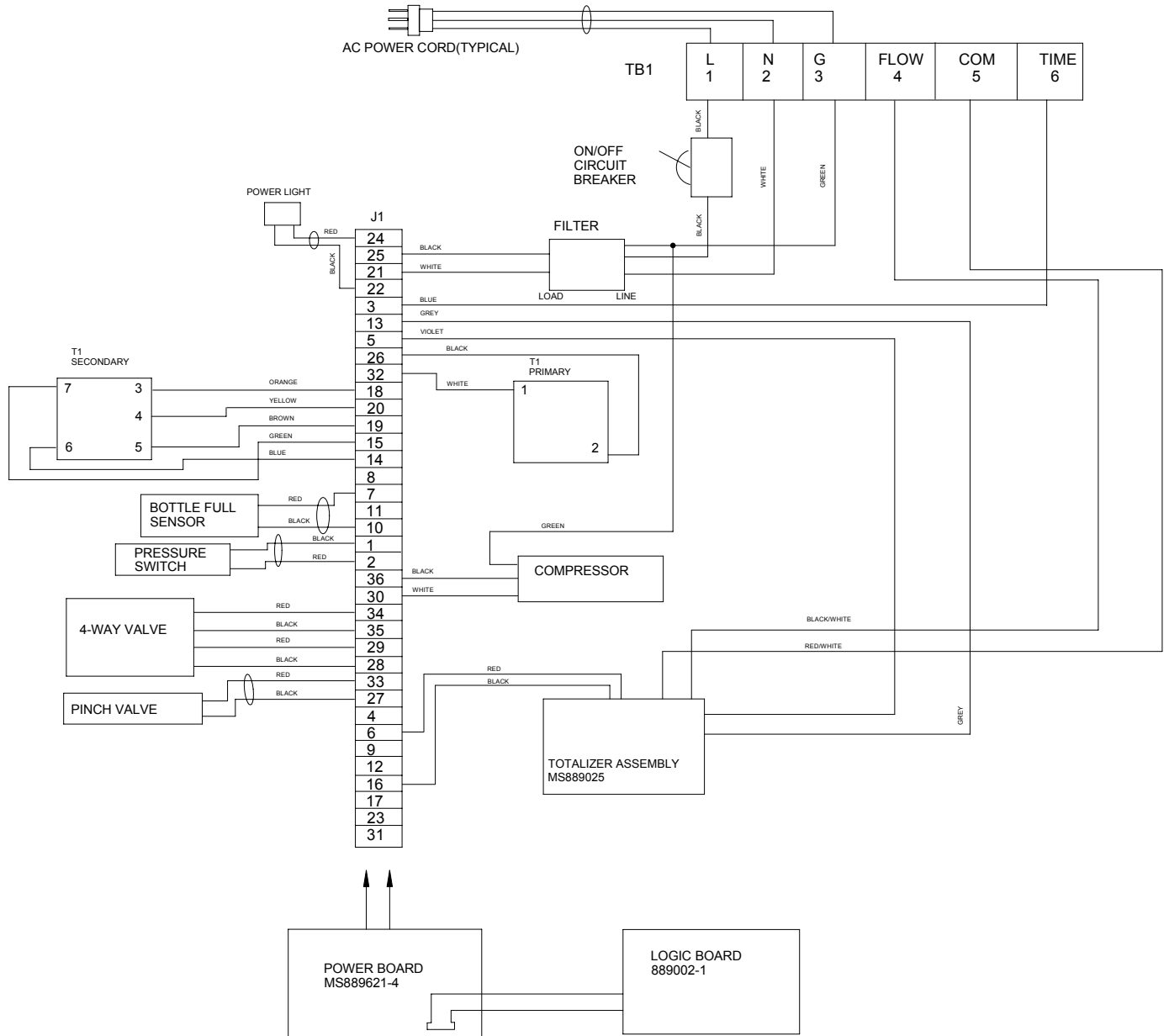

Figure A-15. S-5000 Wiring Diagram with Totalizer

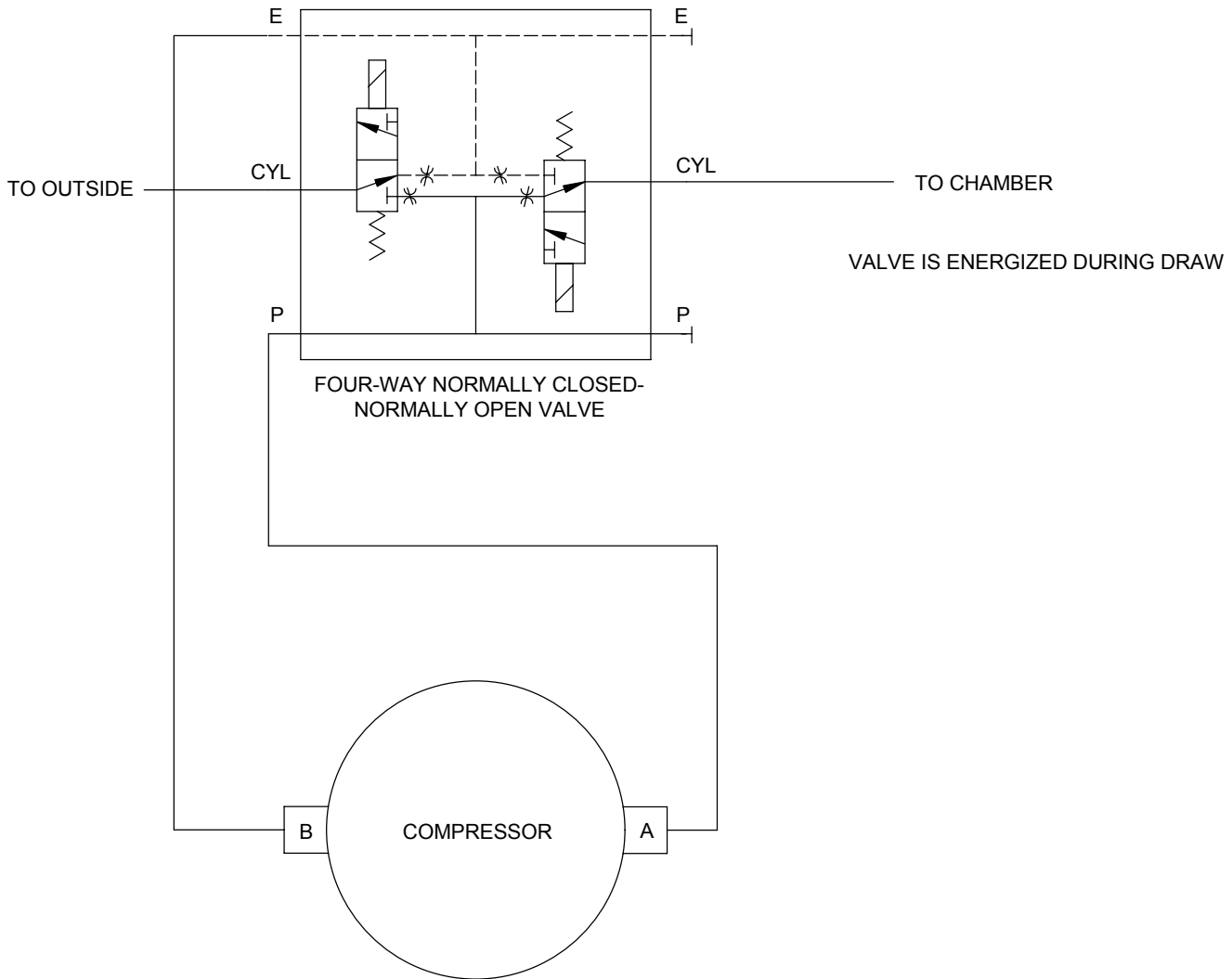

Figure A-16. S-5000 Air System Diagram